



DEMOLITION TOOLS FOR HYDRAULIC MOUNTED BREAKERS



BLUNT



CROSS-CUT FLAT



IN-LINE FLAT



MOIL POINT



CONICAL POINT



DECK BUSTER

**A TRADITION OF
VALUE
THRU
PERFORMANCE!
SINCE 1946**





To Inquire, please have the following information available.
 1) Manufacture & Model Number of hydraulic breaker 2) Type of Point Style

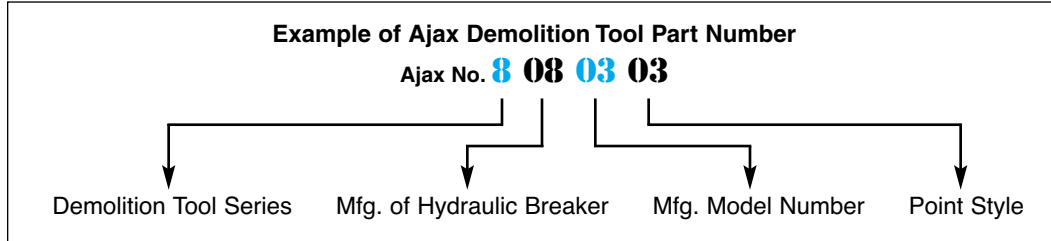

POINT STYLES

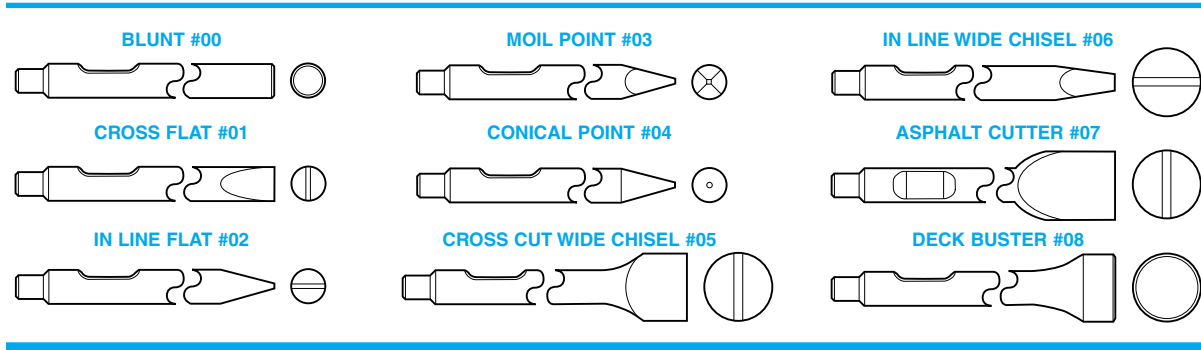

SPECIAL APPLICATION BITS

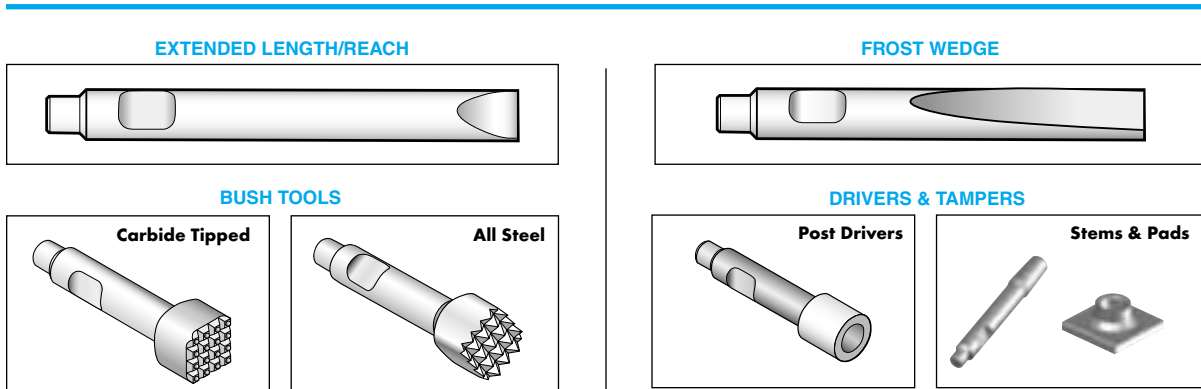

Call Today, Let AJAX Engineer the Right Tool for Special Applications
800.323.9129 or 847.455.5420

TERMS:

This supersedes all previous price list . All prices are net, F.O.B. Franklin Park Illinois
Terms: NET 30 DAYS VISA and MASTERCARD accepted
 Prices do not include Illinois Occupational Tax or other states sales or use taxes.
 These will be added to Invoice when applicable.
 All prices are subject to change without notice. All agreements contingent upon strikes,
 accidents and other delays beyond our control.



Made in the USA
 DPB05



DEMOLITION TOOL PRICING

| PART No. | Point Description | WT lbs | O.A.L. | DIA. inch | Collar inch | No. of Slots | Shank Dia. In. | LIST PRICE |
|---|----------------------------|--------|---------|-----------|-------------|--------------|----------------|------------|
| * ALLIED-KRUPP AR070 | | | | | | | | |
| 8013600 | Blunt End | | 26 3/4" | 2.7500 | | 1 | | 341.00 |
| 8013601 | Flat Chisel Cross Cut | | | | | | | 341.00 |
| 8013602 | Flat Chisel In Line | | | | | | | 341.00 |
| 8013603 | Moil Point | | | | | | | 341.00 |
| 8013604 | Conical Point | | | | | | | 341.00 |
| * ALLIED-KRUPP AR095 | | | | | | | | |
| 8013900 | Blunt End | 110 | 35 5/8" | 3.7240 | N/A | 1 | | 634.00 |
| 8013901 | Flat Chisel Cross Cut | | | | | | | 634.00 |
| 8013902 | Flat Chisel In Line | | | | | | | 634.00 |
| 8013903 | Moil Point | | | | | | | 634.00 |
| 8013904 | Conical Point | | | | | | | 634.00 |
| * ALLIED-KRUPP AR130 | | | | | | | | |
| 8013700 | Blunt End | | 43 3/8" | 5.1100 | | 2 | | 1,230.00 |
| 8013701 | Flat Chisel Cross Cut | | | | | | | 1,230.00 |
| 8013702 | Flat Chisel In Line | | | | | | | 1,230.00 |
| 8013703 | Moil Point | | | | | | | 1,230.00 |
| 8013704 | Conical Point | | | | | | | 1,230.00 |
| ALLIED-KRUPP AS342 | | | | | | | | |
| 8012800 | Blunt End | 9 | 16 | 1.6540 | | 1 | | 123.00 |
| 8012801 | Flat Chisel Cross Cut | | | | | | | 123.00 |
| 8012802 | Flat Chisel In Line | | | | | | | 123.00 |
| 8012803 | Moil Point | | | | | | | 123.00 |
| 8012804 | Conical Point | | | | | | | 123.00 |
| ALLIED-KRUPP AS352 | | | | | | | | |
| 8012900 | Blunt End | 19 | 21 | 2.0470 | | 1 | | 165.00 |
| 8012901 | Flat Chisel Cross Cut | | | | | | | 165.00 |
| 8012902 | Flat Chisel In Line | | | | | | | 165.00 |
| 8012903 | Moil Point | | | | | | | 165.00 |
| 8012904 | Conical Point | | | | | | | 165.00 |
| ALLIED-KRUPP AS362 | | | | | | | | |
| 8013000 | Blunt End | 26 | 23 1/2" | 2.4410 | | 1 | | 219.00 |
| 8013001 | Flat Chisel Cross Cut | | | | | | | 219.00 |
| 8013002 | Flat Chisel In Line | | | | | | | 219.00 |
| 8013003 | Moil Point | | | | | | | 219.00 |
| 8013004 | Conical Point | | | | | | | 219.00 |
| * ALLIED-KRUPP AS370 | | | | | | | | |
| 8013100 | Blunt End | 40 | 29 | 2.7560 | | 1 | | 318.00 |
| 8013101 | Flat Chisel Cross Cut | | | | | | | 318.00 |
| 8013102 | Flat Chisel In Line | | | | | | | 318.00 |
| 8013103 | Moil Point | | | | | | | 318.00 |
| 8013104 | Conical Point | | | | | | | 318.00 |
| * ALLIED-KRUPP AS380 | | | | | | | | |
| 8013200 | Blunt End | 62 | 31 1/2" | 3.1500 | | 1 | | 415.00 |
| 8013201 | Flat Chisel Cross Cut | | | | | | | 415.00 |
| 8013202 | Flat Chisel In Line | | | | | | | 415.00 |
| 8013203 | Moil Point | | | | | | | 415.00 |
| 8013204 | Conical Point | | | | | | | 415.00 |
| * ALLIED-KRUPP HY-RAM 88 | | | | | | | | |
| 8013300 | Blunt End | | 33 | 3.9650 | | 1 | 3.9240 | 1,035.00 |
| 8013301 | Flat Chisel Cross Cut | | | | | | | 1,035.00 |
| 8013302 | Flat Chisel In Line | | | | | | | 1,035.00 |
| 8013303 | Moil Point | | | | | | | 1,035.00 |
| 8013304 | Conical Point | | | | | | | 1,035.00 |
| ALLIED-KRUPP 690 | | | | | | | | |
| 8010100 | Blunt End | 11 | 18 1/2" | 1.6540 | | 1 | 1.2600 | 143.00 |
| 8010101 | Flat Chisel Cross Cut | | | | | | | 143.00 |
| 8010102 | Flat Chisel In Line | | | | | | | 143.00 |
| 8010103 | Moil Point | | | | | | | 143.00 |
| 8010104 | Conical Point | | | | | | | 143.00 |
| AJAX TAMPING PADS- stems sold seperately | | | | | | | | |
| 8000001 | 8"x8" Square Tamping Pad | | | | | | | \$750.00 |
| 8000002 | 12"x12" Square Tamping Pad | | | | | | | \$1,100.00 |

**Note other point styles and lengths available upon request.



DEMOLITION TOOL PRICING

| PART No. | Point Description | WT lbs | O.A.L. | DIA. inch | Collar inch | No. of Slots | Shank Dia. In. | LIST PRICE |
|---|----------------------------|--------|---------|-----------|-------------|--------------|----------------|------------|
| ALLIED-KRUPP 700 | | | | | | | | |
| 8010200 | Blunt End | 15 | 22" | 1.7720 | | 1 | 1.4170 | 146.00 |
| 8010201 | Flat Chisel Cross Cut | | | | | | | 146.00 |
| 8010202 | Flat Chisel In Line | | | | | | | 146.00 |
| 8010203 | Moil Point | | | | | | | 146.00 |
| 8010204 | Conical Point | | | | | | | 146.00 |
| * ALLIED-KRUPP 700 B/AR 048 | | | | | | | | |
| 8010300 | Blunt End | 15 | 20" | 1.8900 | | 1 | 1.2600 | 137.00 |
| 8010301 | Flat Chisel Cross Cut | | | | | | | 137.00 |
| 8010302 | Flat Chisel In Line | | | | | | | 137.00 |
| 8010303 | Moil Point | | | | | | | 137.00 |
| 8010304 | Conical Point | | | | | | | 137.00 |
| * ALLIED-KRUPP 710/710B/711 | | | | | | | | |
| 8010400 | Blunt End | | 23" | 2.1630 | | 1 | 1.7350 | 201.00 |
| 8010401 | Flat Chisel Cross Cut | | | | | | | 201.00 |
| 8010402 | Flat Chisel In Line | | | | | | | 201.00 |
| 8010403 | Moil Point | | | | | | | 201.00 |
| 8010404 | Conical Point | | | | | | | 201.00 |
| ALLIED-KRUPP 711B | | | | | | | | |
| 8010500 | Blunt End | 26 | 23 1/2" | 2.4410 | | 1 | 1.7320 | 242.00 |
| 8010501 | Flat Chisel Cross Cut | | | | | | | 242.00 |
| 8010502 | Flat Chisel In Line | | | | | | | 242.00 |
| 8010503 | Moil Point | | | | | | | 242.00 |
| 8010504 | Conical Point | | | | | | | 242.00 |
| ALLIED-KRUPP 715 B | | | | | | | | |
| 8010700 | Blunt End | 40 | 31 1/2" | 2.5590 | | 1 | 1.8900 | 297.00 |
| 8010701 | Flat Chisel Cross Cut | | | | | | | 297.00 |
| 8010702 | Flat Chisel In Line | | | | | | | 297.00 |
| 8010703 | Moil Point | | | | | | | 297.00 |
| 8010704 | Conical Point | | | | | | | 297.00 |
| ALLIED-KRUPP 725 B | | | | | | | | |
| 8010800 | Blunt End | 55 | 32 1/2" | 2.9530 | | 1 | 2.2440 | 398.00 |
| 8010801 | Flat Chisel Cross Cut | | | | | | | 398.00 |
| 8010802 | Flat Chisel In Line | | | | | | | 398.00 |
| 8010803 | Moil Point | | | | | | | 398.00 |
| 8010804 | Conical Point | | | | | | | 398.00 |
| * ALLIED-KRUPP 750 B /750 CS/ HM 720 | | | | | | | | |
| 8012700 | Blunt End | | 39 | 4.4850 | | 2 | | 952.00 |
| 8012701 | Flat Chisel Cross Cut | | | | | | | 952.00 |
| 8012702 | Flat Chisel In Line | | | | | | | 952.00 |
| 8012703 | Moil Point | | | | | | | 952.00 |
| 8012704 | Conical Point | | | | | | | 952.00 |
| * ALLIED-KRUPP 730 | | | | | | | | |
| 8011000 | Blunt End | 66 | 35 1/2" | 3.1500 | | 1 | 2.3620 | 463.00 |
| 8011001 | Flat Chisel Cross Cut | | | | | | | 463.00 |
| 8011002 | Flat Chisel In Line | | | | | | | 463.00 |
| 8011003 | Moil Point | | | | | | | 463.00 |
| 8011004 | Conical Point | | | | | | | 463.00 |
| ALLIED-KRUPP 735 CS | | | | | | | | |
| 8011200 | Blunt End | 88 | 35 1/2" | 3.5430 | | 1 | 2.7170 | 540.00 |
| 8011201 | Flat Chisel Cross Cut | | | | | | | 540.00 |
| 8011202 | Flat Chisel In Line | | | | | | | 540.00 |
| 8011203 | Moil Point | | | | | | | 540.00 |
| 8011204 | Conical Point | | | | | | | 540.00 |
| * ALLIED-KRUPP 740 CS | | | | | | | | |
| 8011300 | Blunt End | 117 | 39 1/2" | 3.9370 | | 1 | 2.9530 | 702.00 |
| 8011301 | Flat Chisel Cross Cut | | | | | | | 702.00 |
| 8011302 | Flat Chisel In Line | | | | | | | 702.00 |
| 8011303 | Moil Point | | | | | | | 702.00 |
| 8011304 | Conical Point | | | | | | | 702.00 |
| AJAX TAMPING PADS- stems sold seperately | | | | | | | | |
| 8000001 | 8"x8" Square Tamping Pad | | | | | | | \$750.00 |
| 8000002 | 12"x12" Square Tamping Pad | | | | | | | \$1,100.00 |

**Note other point styles and lengths available upon request.



DEMOLITION TOOL PRICING



| PART No. | Point Description | WT lbs | O.A.L. | DIA. inch | Collar inch | No. of Slots | Shank Dia. In. | LIST PRICE |
|--|----------------------------|--------|---------|-----------|-------------|--------------|----------------|------------|
| * ALLIED-KRUPP 770 CS | | | | | | | | |
| 8012100 | Blunt End | 234 | 43 1/2" | 5.3150 | | 2 | | 1,269.00 |
| 8012101 | Flat Chisel Cross Cut | | | | | | | 1,269.00 |
| 8012102 | Flat Chisel In Line | | | | | | | 1,269.00 |
| 8012103 | Moil Point | | | | | | | 1,269.00 |
| 8012104 | Conical Point | | | | | | | 1,269.00 |
| * ALLIED-KRUPP 780 CS/785 CS | | | | | | | | |
| 8012400 | Blunt End | 344 | 51" | 5.9060 | | 2 | | 1,861.00 |
| 8012401 | Flat Chisel Cross Cut | | | | | | | 1,861.00 |
| 8012402 | Flat Chisel In Line | | | | | | | 1,861.00 |
| 8012403 | Moil Point | | | | | | | 1,861.00 |
| 8012404 | Conical Point | | | | | | | 1,861.00 |
| ALLIED-KRUPP 795 CS | | | | | | | | |
| 8012500 | Blunt End | 403 | 51" | 6.2990 | | 2 | | 2,227.00 |
| 8012501 | Flat Chisel Cross Cut | | | | | | | 2,227.00 |
| 8012502 | Flat Chisel In Line | | | | | | | 2,227.00 |
| 8012503 | Moil Point | | | | | | | 2,227.00 |
| 8012504 | Conical Point | | | | | | | 2,227.00 |
| * ALLIED-KRUPP 797 CS | | | | | | | | |
| 8013500 | Blunt End | | 57 1/4" | 6.4700 | | 2 | | 2,849.00 |
| 8013501 | Flat Chisel Cross Cut | | | | | | | 2,849.00 |
| 8013502 | Flat Chisel In Line | | | | | | | 2,849.00 |
| 8013503 | Moil Point | | | | | | | 2,849.00 |
| 8013504 | Conical Point | | | | | | | 2,849.00 |
| ALLIED-KRUPP805 CS | | | | | | | | |
| 8012600 | Blunt End | 595 | 57" | 7.0870 | | 2 | | 3,875.00 |
| 8012601 | Flat Chisel Cross Cut | | | | | | | 3,875.00 |
| 8012602 | Flat Chisel In Line | | | | | | | 3,875.00 |
| 8012603 | Moil Point | | | | | | | 3,875.00 |
| 8012604 | Conical Point | | | | | | | 3,875.00 |
| ALLIED-KRUPP HM77 | | | | | | | | |
| 8013800 | Blunt End | | 31" | 3.1350 | 3.9300 | 1 | 3.1350 | 737.00 |
| 8013801 | Flat Chisel Cross Cut | | | | | | | 737.00 |
| 8013802 | Flat Chisel In Line | | | | | | | 737.00 |
| 8013803 | Moil Point | | | | | | | 737.00 |
| 8013804 | Conical Point | | | | | | | 737.00 |
| ALLIED-KRUPP HM 85/HM90V | | | | | | | | |
| 8010500 | Blunt End | 26 | 23 1/2" | 2.4410 | | 1 | 1.7320 | 242.00 |
| 8010501 | Flat Chisel Cross Cut | | | | | | | 242.00 |
| 8010502 | Flat Chisel In Line | | | | | | | 242.00 |
| 8010503 | Moil Point | | | | | | | 242.00 |
| 8010504 | Conical Point | | | | | | | 242.00 |
| * ALLIED-KRUPP HM110/100/720 | | | | | | | | |
| 8010600 | Blunt End | 35 | 27 1/2" | 2.5590 | 3.3420 | 1 | | 424.00 |
| 8010601 | Flat Chisel Cross Cut | | | | | | | 424.00 |
| 8010602 | Flat Chisel In Line | | | | | | | 424.00 |
| 8010603 | Moil Point | | | | | | | 424.00 |
| 8010604 | Conical Point | | | | | | | 424.00 |
| ALLIED-KRUPP HM200 | | | | | | | | |
| 8010900 | Blunt End | 73 | 36" | 3.1500 | | 1 | | 663.00 |
| 8010901 | Flat Chisel Cross Cut | | | | | | | 663.00 |
| 8010902 | Flat Chisel In Line | | | | | | | 663.00 |
| 8010903 | Moil Point | | | | | | | 663.00 |
| 8010904 | Conical Point | | | | | | | 663.00 |
| ALLIED-KRUPP HM 580 | | | | | | | | |
| 8011400 | Blunt End | 117 | 39 1/2" | 3.9370 | | 1 | | 709.00 |
| 8011401 | Flat Chisel Cross Cut | | | | | | | 709.00 |
| 8011402 | Flat Chisel In Line | | | | | | | 709.00 |
| 8011403 | Moil Point | | | | | | | 709.00 |
| 8011404 | Conical Point | | | | | | | 709.00 |
| AJAX TAMPING PADS - stems sold seperately | | | | | | | | |
| 8000001 | 8"x8" Square Tamping Pad | | | | | | | \$750.00 |
| 8000002 | 12"x12" Square Tamping Pad | | | | | | | \$1,100.00 |

**Note other point styles and lengths available upon request.



DEMOLITION TOOL PRICING

| PART No. | Point Description | WT lbs | O.A.L. | DIA. inch | Collar inch | No. of Slots | Shank Dia. In. | LIST PRICE |
|---|----------------------------|--------|---------|-----------|-------------|--------------|----------------|------------|
| ALLIED-KRUPP HM 600 | | | | | | | | |
| 8011500 | Blunt End | 130 | 39 1/2" | 3.9370 | | 1 | | 970.00 |
| 8011501 | Flat Chisel Cross Cut | | | | | | | 970.00 |
| 8011502 | Flat Chisel In Line | | | | | | | 970.00 |
| 8011503 | Moil Point | | | | | | | 970.00 |
| 8011504 | Conical Point | | | | | | | 970.00 |
| ALLIED-KRUPP HM 700 | | | | | | | | |
| 8011600 | Blunt End | 185 | 43 1/2" | 4.5280 | | 2 | 3.1500 | 1,134.00 |
| 8011601 | Flat Chisel Cross Cut | | | | | | | 1,134.00 |
| 8011602 | Flat Chisel In Line | | | | | | | 1,134.00 |
| 8011603 | Moil Point | | | | | | | 1,134.00 |
| 8011604 | Conical Point | | | | | | | 1,134.00 |
| * ALLIED-KRUPP HM 780/755 CS | | | | | | | | |
| 8011800 | Blunt End | 192 | 43 1/2" | 4.7240 | | 2 | | 1,103.00 |
| 8011801 | Flat Chisel Cross Cut | | | | | | | 1,103.00 |
| 8011802 | Flat Chisel In Line | | | | | | | 1,103.00 |
| 8011803 | Moil Point | | | | | | | 1,103.00 |
| 8011804 | Conical Point | | | | | | | 1,103.00 |
| ALLIED-KRUPP HM 800 | | | | | | | | |
| 8011900 | Blunt End | | | 5.3150 | | 2 | 4.1340 | 1,535.00 |
| 8011901 | Flat Chisel Cross Cut | | | | | | | 1,535.00 |
| 8011902 | Flat Chisel In Line | | | | | | | 1,535.00 |
| 8011903 | Moil Point | | | | | | | 1,535.00 |
| 8011904 | Conical Point | | | | | | | 1,535.00 |
| ALLIED-KRUPP HM 900 | | | | | | | | |
| 8012000 | Blunt End | | | 5.3150 | | 2 | 4.1340 | 1,535.00 |
| 8012001 | Flat Chisel Cross Cut | | | | | | | 1,535.00 |
| 8012002 | Flat Chisel In Line | | | | | | | 1,535.00 |
| 8012003 | Moil Point | | | | | | | 1,535.00 |
| 8012004 | Conical Point | | | | | | | 1,535.00 |
| ALLIED-KRUPP HM 1000V/ HM 775CS | | | | | | | | |
| 8012200 | Blunt End | 287 | 47" | 5.5120 | | 2 | | 1,541.00 |
| 8012201 | Flat Chisel Cross Cut | | | | | | | 1,541.00 |
| 8012202 | Flat Chisel In Line | | | | | | | 1,541.00 |
| 8012203 | Moil Point | | | | | | | 1,541.00 |
| 8012204 | Conical Point | | | | | | | 1,541.00 |
| * ALLIED-KRUPP HO RAM 7000B | | | | | | | | |
| 8013400 | Blunt End | | 35 1/2" | 3.9500 | | 1 | 3.9340 | 1,096.00 |
| 8013401 | Flat Chisel Cross Cut | | | | | | | 1,096.00 |
| 8013402 | Flat Chisel In Line | | | | | | | 1,096.00 |
| 8013403 | Moil Point | | | | | | | 1,096.00 |
| 8013404 | Conical Point | | | | | | | 1,096.00 |
| ATLAS COPCO HBC 1100/1700 HD | | | | | | | | |
| 8210800 | Blunt End | 117 | 35 1/2" | 4.1340 | | 2 | | 680.00 |
| 8210801 | Flat Chisel Cross Cut | | | | | | | 680.00 |
| 8210802 | Flat Chisel In Line | | | | | | | 680.00 |
| 8210803 | Moil Point | | | | | | | 680.00 |
| 8210804 | Conical Point | | | | | | | 680.00 |
| ATLAS COPCO HBC 2500 | | | | | | | | |
| 8210900 | Blunt End | 190 | 39 1/2" | 4.9210 | | 2 | | 1,066.00 |
| 8210901 | Flat Chisel Cross Cut | | | | | | | 1,066.00 |
| 8210902 | Flat Chisel In Line | | | | | | | 1,066.00 |
| 8210903 | Moil Point | | | | | | | 1,066.00 |
| 8210904 | Conical Point | | | | | | | 1,066.00 |
| ATLAS COPCO HBC 4000 HD | | | | | | | | |
| 8211000 | Blunt End | 238 | 43 1/2" | 5.3150 | | 2 | | 1,258.00 |
| 8211001 | Flat Chisel Cross Cut | | | | | | | 1,258.00 |
| 8211002 | Flat Chisel In Line | | | | | | | 1,258.00 |
| 8211003 | Moil Point | | | | | | | 1,258.00 |
| 8211004 | Conical Point | | | | | | | 1,258.00 |
| AJAX TAMPING PADS- stems sold seperately | | | | | | | | |
| 8000001 | 8"x8" Square Tamping Pad | | | | | | | \$750.00 |
| 8000002 | 12"x12" Square Tamping Pad | | | | | | | \$1,100.00 |

**Note other point styles and lengths available upon request.



DEMOLITION TOOL PRICING



| PART No. | Point Description | WT lbs | O.A.L. | DIA. inch | Collar inch | No. of Slots | Shank Dia. In. | LIST PRICE |
|--|----------------------------|--------|---------|-----------|-------------|--------------|----------------|------------|
| ATLAS COPCO HBC 6000 | | | | | | | | |
| 8211100 | Blunt End | 507 | 56 1/2" | 6.6930 | | 2 | | 3,588.00 |
| 8211101 | Flat Chisel Cross Cut | | | | | | | 3,588.00 |
| 8211102 | Flat Chisel In Line | | | | | | | 3,588.00 |
| 8211103 | Moil Point | | | | | | | 3,588.00 |
| 8211104 | Conical Point | | | | | | | 3,588.00 |
| ATLAS COPCO SBC 60 Same as Mini Brock | | | | | | | | |
| 8210300 | Blunt End | 6 | 16" | 1.2500 | | 2 | | 75.00 |
| 8210301 | Flat Chisel Cross Cut | | | | | | | 75.00 |
| 8210302 | Flat Chisel In Line | | | | | | | 75.00 |
| 8210303 | Moil Point | | | | | | | 75.00 |
| 8210304 | Conical Point | | | | | | | 75.00 |
| ATLAS COPCO SBC 115 | | | | | | | | |
| 8210400 | Blunt End | 14 | 21 1/2" | 1.7720 | | 2 | | 147.00 |
| 8210401 | Flat Chisel Cross Cut | | | | | | | 147.00 |
| 8210402 | Flat Chisel In Line | | | | | | | 147.00 |
| 8210403 | Moil Point | | | | | | | 147.00 |
| 8210404 | Conical Point | | | | | | | 147.00 |
| * ATLAS COPCO SBC 255 Same as Brock 90 | | | | | | | | |
| 8210500 | Blunt End | 14 | 20" | 1.9690 | | 2 | | 149.00 |
| 8210501 | Flat Chisel Cross Cut | | | | | | | 149.00 |
| 8210502 | Flat Chisel In Line | | | | | | | 149.00 |
| 8210503 | Moil Point | | | | | | | 149.00 |
| 8210504 | Conical Point | | | | | | | 149.00 |
| * ATLAS COPCO SBC 410 Same as Brock 150/180 | | | | | | | | |
| 8210100 | Blunt End | 29 | 23 1/2" | 2.5590 | | 2 | | 238.00 |
| 8210101 | Flat Chisel Cross Cut | | | | | | | 238.00 |
| 8210102 | Flat Chisel In Line | | | | | | | 238.00 |
| 8210103 | Moil Point | | | | | | | 238.00 |
| 8210104 | Conical Point | | | | | | | 238.00 |
| * ATLAS COPCO SBC 610 Same as Brock 150/180 | | | | | | | | |
| 8210700 | Blunt End | 57 | 31 1/2" | 3.1500 | | 2 | | 409.00 |
| 8210701 | Flat Chisel Cross Cut | | | | | | | 409.00 |
| 8210702 | Flat Chisel In Line | | | | | | | 409.00 |
| 8210703 | Moil Point | | | | | | | 409.00 |
| 8210704 | Conical Point | | | | | | | 409.00 |
| * ATLAS COPCO SBC 800/810/850 Same as Brock 330 | | | | | | | | |
| 8210200 | Blunt End | 88 | 33" | 3.7400 | | 2 | | 574.00 |
| 8210201 | Flat Chisel Cross Cut | | | | | | | 574.00 |
| 8210202 | Flat Chisel In Line | | | | | | | 574.00 |
| 8210203 | Moil Point | | | | | | | 574.00 |
| 8210204 | Conical Point | | | | | | | 574.00 |
| ATLAS COPCO TEX 250 H1 | | | | | | | | |
| 8210600 | Blunt End | 60 | 31 1/2" | 3.1500 | | 2 | | 409.00 |
| 8210601 | Flat Chisel Cross Cut | | | | | | | 409.00 |
| 8210602 | Flat Chisel In Line | | | | | | | 409.00 |
| 8210603 | Moil Point | | | | | | | 409.00 |
| 8210604 | Conical Point | | | | | | | 409.00 |
| * B & D | | | | | | | | |
| 8320100 | Blunt End | | 53 | 6.0920 | | 2 | 4.7480 | 2,897.00 |
| 8320101 | Flat Chisel Cross Cut | | | | | | | 2,897.00 |
| 8320102 | Flat Chisel In Line | | | | | | | 2,897.00 |
| 8320103 | Moil Point | | | | | | | 2,897.00 |
| 8320104 | Conical Point | | | | | | | 2,897.00 |
| * BOBCAT 850/950 | | | | | | | | |
| 8020500 | Blunt End | | 23 | 2.4350 | | 2 | | 235.00 |
| 8020501 | Flat Chisel Cross Cut | | | | | | | 235.00 |
| 8020502 | Flat Chisel In Line | | | | | | | 235.00 |
| 8020503 | Moil Point | | | | | | | 235.00 |
| 8020504 | Conical Point | | | | | | | 235.00 |
| AJAX TAMPING PADS- stems sold seperately | | | | | | | | |
| 8000001 | 8"x8" Square Tamping Pad | | | | | | | \$750.00 |
| 8000002 | 12"x12" Square Tamping Pad | | | | | | | \$1,100.00 |

**Note other point styles and lengths available upon request.



DEMOLITION TOOL PRICING

| PART No. | Point Description | WT lbs | O.A.L. | DIA. inch | Collar inch | No. of Slots | Shank Dia. In. | LIST PRICE |
|---|----------------------------|--|---------|-----------|-------------|--------------|----------------|------------|
| BOBCAT 1250 | | | | | | | | |
| 8020300 | Blunt End | 11 | 19" | 1.7720 | | 1 | 1.1810 | 123.00 |
| 8020301 | Flat Chisel Cross Cut | | | | | | | 123.00 |
| 8020302 | Flat Chisel In Line | | | | | | | 123.00 |
| 8020303 | Moil Point | | | | | | | 123.00 |
| 8020304 | Conical Point | | | | | | | 123.00 |
| BOBCAT 1750 | | | | | | | | |
| 8020100 | Blunt End | 11 | 19" | 1.7320 | | 1.0000 | | 112.00 |
| 8020101 | Flat Chisel Cross Cut | | | | | | | 112.00 |
| 8020102 | Flat Chisel In Line | | | | | | | 112.00 |
| 8020103 | Moil Point | | | | | | | 112.00 |
| 8020104 | Conical Point | | | | | | | 112.00 |
| * BOBCAT 2500/2570/3570 | | Same as Stanley MB250/256/350/356 | | | | | | |
| 8020400 | Blunt End | 29 | 22" | 2.5000 | | 1 | | 201.00 |
| 8020401 | Flat Chisel Cross Cut | | | | | | | 201.00 |
| 8020402 | Flat Chisel In Line | | | | | | | 201.00 |
| 8020403 | Moil Point | | | | | | | 201.00 |
| 8020404 | Conical Point | | | | | | | 201.00 |
| * BTI/TELEDYNE TB 120/125 | | | | | | | | |
| 8190200 | Blunt End | 13 | 20" | 1.9690 | | 2 | 1.3860 | 166.00 |
| 8190201 | Flat Chisel Cross Cut | | | | | | | 166.00 |
| 8190202 | Flat Chisel In Line | | | | | | | 166.00 |
| 8190203 | Moil Point | | | | | | | 166.00 |
| 8190204 | Conical Point | | | | | | | 166.00 |
| * BTI/TELEDYNE TB 220/325 | | | | | | | | |
| 8190600 | Blunt End | 48 | 28" | 2.9380 | | 2 | 2.0550 | 371.00 |
| 8190601 | Flat Chisel Cross Cut | | | | | | | 371.00 |
| 8190602 | Flat Chisel In Line | | | | | | | 371.00 |
| 8190603 | Moil Point | | | | | | | 371.00 |
| 8190604 | Conical Point | | | | | | | 371.00 |
| BTI/TELEDYNE TB 225CM | | | | | | | | |
| 8190300 | Blunt End | 24 | 23 1/2" | 2.2830 | | 1 | | 197.00 |
| 8190301 | Flat Chisel Cross Cut | | | | | | | 197.00 |
| 8190302 | Flat Chisel In Line | | | | | | | 197.00 |
| 8190303 | Moil Point | | | | | | | 197.00 |
| 8190304 | Conical Point | | | | | | | 197.00 |
| * BTI/TELEDYNE TB 245 | | | | | | | | |
| 8191800 | Blunt End | | 23 1/4" | 2.2830 | | 2 | 1.8110 | 235.00 |
| 8191801 | Flat Chisel Cross Cut | | | | | | | 235.00 |
| 8191802 | Flat Chisel In Line | | | | | | | 235.00 |
| 8191803 | Moil Point | | | | | | | 235.00 |
| 8191804 | Conical Point | | | | | | | 235.00 |
| * BTI/TELEDYNE TB 275 | | | | | | | | |
| 8190400 | Blunt End | 24 | 25 1/4" | 2.5150 | | 2 | 1.9680 | 253.00 |
| 8190401 | Flat Chisel Cross Cut | | | | | | | 253.00 |
| 8190402 | Flat Chisel In Line | | | | | | | 253.00 |
| 8190403 | Moil Point | | | | | | | 253.00 |
| 8190404 | Conical Point | | | | | | | 253.00 |
| * BTI/TELEDYNE TB 400/425CM/425X/625 CM/625X | | | | | | | | |
| 8190700 | Blunt End | 88 | 33" | 3.7280 | | 2 | 2.3600 | 599.00 |
| 8190701 | Flat Chisel Cross Cut | | | | | | | 599.00 |
| 8190702 | Flat Chisel In Line | | | | | | | 599.00 |
| 8190703 | Moil Point | | | | | | | 599.00 |
| 8190704 | Conical Point | | | | | | | 599.00 |
| * BTI/TELEDYNE TB 725CM/725X/825X | | | | | | | | |
| 8190800 | Blunt End | 161 | 37" | 4.5280 | | 2 | 3.5430 | 961.00 |
| 8190801 | Flat Chisel Cross Cut | | | | | | | 961.00 |
| 8190802 | Flat Chisel In Line | | | | | | | 961.00 |
| 8190803 | Moil Point | | | | | | | 961.00 |
| 8190804 | Conical Point | | | | | | | 961.00 |
| AJAX TAMPING PADS - stems sold seperately | | | | | | | | |
| 8000001 | 8"x8" Square Tamping Pad | | | | | | | \$750.00 |
| 8000002 | 12"x12" Square Tamping Pad | | | | | | | \$1,100.00 |

**Note other point styles and lengths available upon request.



DEMOLITION TOOL PRICING



| PART No. | Point Description | WT lbs | O.A.L. | DIA. inch | Collar inch | No. of Slots | Shank Dia. In. | LIST PRICE |
|--|----------------------------|--------|---------|-----------|-------------|--------------|----------------|------------|
| * BTI/TELEDYNE TB 730/830 | | | | | | | | |
| 8191100 | Blunt End | | 37" | 4.5140 | | 2 | 3.5430 | 932.00 |
| 8191101 | Flat Chisel Cross Cut | | | | | | | 932.00 |
| 8191102 | Flat Chisel In Line | | | | | | | 932.00 |
| 8191103 | Moil Point | | | | | | | 932.00 |
| 8191104 | Conical Point | | | | | | | 932.00 |
| * BTI/TELEDYNE TB 900 | | | | | | | | |
| 8191200 | Blunt End | | 46" | 5.3000 | | 2 | 4.1340 | 1,447.00 |
| 8191201 | Flat Chisel Cross Cut | | | | | | | 1,447.00 |
| 8191202 | Flat Chisel In Line | | | | | | | 1,447.00 |
| 8191203 | Moil Point | | | | | | | 1,447.00 |
| 8191204 | Conical Point | | | | | | | 1,447.00 |
| * BTI/TELEDYNE TB 925X/975X | | | | | | | | |
| 8190900 | Blunt End | 247 | 47" | 5.3150 | | 2 | 4.1030 | 1,459.00 |
| 8190901 | Flat Chisel Cross Cut | | | | | | | 1,459.00 |
| 8190902 | Flat Chisel In Line | | | | | | | 1,459.00 |
| 8190903 | Moil Point | | | | | | | 1,459.00 |
| 8190904 | Conical Point | | | | | | | 1,459.00 |
| * BTI/TELEDYNE TB 930 | | | | | | | | |
| 8191700 | Blunt End | | 51" | 5.3000 | | 2 | 4.1340 | 1,564.00 |
| 8191701 | Flat Chisel Cross Cut | | | | | | | 1,564.00 |
| 8191702 | Flat Chisel In Line | | | | | | | 1,564.00 |
| 8191703 | Moil Point | | | | | | | 1,564.00 |
| 8191704 | Conical Point | | | | | | | 1,564.00 |
| * BTI/TELEDYNE TB 1280 | | | | | | | | |
| 8191300 | Blunt End | 247 | 53" | 5.4900 | | 2 | 4.3310 | 1,751.00 |
| 8191301 | Flat Chisel Cross Cut | | | | | | | 1,751.00 |
| 8191302 | Flat Chisel In Line | | | | | | | 1,751.00 |
| 8191303 | Moil Point | | | | | | | 1,751.00 |
| 8191304 | Conical Point | | | | | | | 1,751.00 |
| * BTI/TELEDYNE TB 1425X/1675X | | | | | | | | |
| 8191000 | Blunt End | 344 | 51" | 5.7480 | | 2 | 4.5280 | 1,918.00 |
| 8191001 | Flat Chisel Cross Cut | | | | | | | 1,918.00 |
| 8191002 | Flat Chisel In Line | | | | | | | 1,918.00 |
| 8191003 | Moil Point | | | | | | | 1,918.00 |
| 8191004 | Conical Point | | | | | | | 1,918.00 |
| * BTI/TELEDYNE TB 1430/1680 | | | | | | | | |
| 8191400 | Blunt End | 344 | 54-3/4" | 5.7260 | | 2 | 4.5260 | 1,748.00 |
| 8191401 | Flat Chisel Cross Cut | | | | | | | 1,748.00 |
| 8191402 | Flat Chisel In Line | | | | | | | 1,748.00 |
| 8191403 | Moil Point | | | | | | | 1,748.00 |
| 8191404 | Conical Point | | | | | | | 1,748.00 |
| * BTI/TELEDYNE TB 2080 | | | | | | | | |
| 8191500 | Blunt End | 344 | 53" | 6.2740 | | 2 | 4.8800 | 2,541.00 |
| 8191501 | Flat Chisel Cross Cut | | | | | | | 2,541.00 |
| 8191502 | Flat Chisel In Line | | | | | | | 2,541.00 |
| 8191503 | Moil Point | | | | | | | 2,541.00 |
| 8191504 | Conical Point | | | | | | | 2,541.00 |
| * BTI/TELEDYNE TB 2580 | | | | | | | | |
| 8191600 | Blunt End | | 53" | 6.9820 | | 2 | 5.1200 | 2,543.00 |
| 8191601 | Flat Chisel Cross Cut | | | | | | | 2,543.00 |
| 8191602 | Flat Chisel In Line | | | | | | | 2,543.00 |
| 8191603 | Moil Point | | | | | | | 2,543.00 |
| 8191604 | Conical Point | | | | | | | 2,543.00 |
| * CATERPILLAR H 45 | | | | | | | | |
| 8030100 | Blunt End | 11 | 19" | 1.7720 | | 1 | | 112.00 |
| 8030101 | Flat Chisel Cross Cut | | | | | | | 112.00 |
| 8030102 | Flat Chisel In Line | | | | | | | 112.00 |
| 8030103 | Moil Point | | | | | | | 112.00 |
| 8030104 | Conical Point | | | | | | | 112.00 |
| AJAX TAMPING PADS - stems sold seperately | | | | | | | | |
| 8000001 | 8"x8" Square Tamping Pad | | | | | | | \$750.00 |
| 8000002 | 12"x12" Square Tamping Pad | | | | | | | \$1,100.00 |

**Note other point styles and lengths available upon request.



DEMOLITION TOOL PRICING

| PART No. | Point Description | WT lbs | O.A.L. | DIA. inch | Collar inch | No. of Slots | Shank Dia. In. | LIST PRICE |
|----------|--|--------|----------------------------|-----------|-------------|--------------|----------------|------------|
| | * CATERPILLAR H 50 | | | | | | | |
| 8030200 | Blunt End | 15 | 20" | 1.9690 | | 2 | | 147.00 |
| 8030201 | Flat Chisel Cross Cut | | | | | | | 147.00 |
| 8030202 | Flat Chisel In Line | | | | | | | 147.00 |
| 8030203 | Moil Point | | | | | | | 147.00 |
| 8030204 | Conical Point | | | | | | | 147.00 |
| | * CATERPILLAR H 63 | | SAME AS JCB - HM260 | | | | | |
| 8030300 | Blunt End | 33 | 27 1/2" | 2.4800 | | 1 | | 271.00 |
| 8030301 | Flat Chisel Cross Cut | | | | | | | 271.00 |
| 8030302 | Flat Chisel In Line | | | | | | | 271.00 |
| 8030303 | Moil Point | | | | | | | 271.00 |
| 8030304 | Conical Point | | | | | | | 271.00 |
| | CATERPILLAR H 70 | | | | | | | |
| 8030400 | Blunt End | 42 | 29" | 2.7560 | | 2 | | 318.00 |
| 8030401 | Flat Chisel Cross Cut | | | | | | | 318.00 |
| 8030402 | Flat Chisel In Line | | | | | | | 318.00 |
| 8030403 | Moil Point | | | | | | | 318.00 |
| 8030404 | Conical Point | | | | | | | 318.00 |
| | CATERPILLAR H 90 | | | | | | | |
| 8030500 | Blunt End | 79 | 35" | 3.5430 | | 1 | 2.9130 | 567.00 |
| 8030501 | Flat Chisel Cross Cut | | | | | | | 567.00 |
| 8030502 | Flat Chisel In Line | | | | | | | 567.00 |
| 8030503 | Moil Point | | | | | | | 567.00 |
| 8030504 | Conical Point | | | | | | | 567.00 |
| | CATERPILLAR H 100 | | | | | | | |
| 8030600 | Blunt End | 88 | 33" | 3.7400 | | 2 | | 588.00 |
| 8030601 | Flat Chisel Cross Cut | | | | | | | 588.00 |
| 8030602 | Flat Chisel In Line | | | | | | | 588.00 |
| 8030603 | Moil Point | | | | | | | 588.00 |
| 8030604 | Conical Point | | | | | | | 588.00 |
| | CATERPILLAR H 115 | | | | | | | |
| 8030800 | Blunt End | 172 | 41 1/2" | 4.5280 | | 1 | | 991.00 |
| 8030801 | Flat Chisel Cross Cut | | | | | | | 991.00 |
| 8030802 | Flat Chisel In Line | | | | | | | 991.00 |
| 8030803 | Moil Point | | | | | | | 991.00 |
| 8030804 | Conical Point | | | | | | | 991.00 |
| | CATERPILLAR H 115 C | | | | | | | |
| 8030700 | Blunt End | 143 | 41 1/2" | 4.1730 | | 2 | | 816.00 |
| 8030701 | Flat Chisel Cross Cut | | | | | | | 816.00 |
| 8030702 | Flat Chisel In Line | | | | | | | 816.00 |
| 8030703 | Moil Point | | | | | | | 816.00 |
| 8030704 | Conical Point | | | | | | | 816.00 |
| | CATERPILLAR H 120C | | | | | | | |
| 8030900 | Blunt End | 172 | 41 1/2" | 4.5280 | | 2 | | 959.00 |
| 8030901 | Flat Chisel Cross Cut | | | | | | | 959.00 |
| 8030902 | Flat Chisel In Line | | | | | | | 959.00 |
| 8030903 | Moil Point | | | | | | | 959.00 |
| 8030904 | Conical Point | | | | | | | 959.00 |
| | * CATERPILLAR H 130 | | SAME AS RAMMER E68 | | | | | |
| 8031100 | Blunt End | 225 | 43 1/2" | 5.1180 | | 1 | | 1,182.00 |
| 8031101 | Flat Chisel Cross Cut | | | | | | | 1,182.00 |
| 8031102 | Flat Chisel In Line | | | | | | | 1,182.00 |
| 8031103 | Moil Point | | | | | | | 1,182.00 |
| 8031104 | Conical Point | | | | | | | 1,182.00 |
| | CATERPILLAR H 130C | | | | | | | |
| 8031000 | Blunt End | 223 | 43 1/2" | 5.1180 | | 2 | | 1,231.00 |
| 8031001 | Flat Chisel Cross Cut | | | | | | | 1,231.00 |
| 8031002 | Flat Chisel In Line | | | | | | | 1,231.00 |
| 8031003 | Moil Point | | | | | | | 1,231.00 |
| 8031004 | Conical Point | | | | | | | 1,231.00 |
| | AJAX TAMPING PADS - stems sold seperately | | | | | | | |
| 8000001 | 8"x8" Square Tamping Pad | | | | | | | \$750.00 |
| 8000002 | 12"x12" Square Tamping Pad | | | | | | | \$1,100.00 |

**Note other point styles and lengths available upon request.



DEMOLITION TOOL PRICING



| PART No. | Point Description | WT lbs | O.A.L. | DIA. inch | Collar inch | No. of Slots | Shank Dia. In. | LIST PRICE |
|--|----------------------------|---------------------------|---------|-----------|-------------|--------------|----------------|------------|
| * CATERPILLAR H 140 | | SAME AS RAMMER S83 | | | | | | |
| 8031200 | Blunt End | 287 | 47" | 5.5120 | | 2 | | 1,541.00 |
| 8031201 | Flat Chisel Cross Cut | | | | | | | 1,541.00 |
| 8031202 | Flat Chisel In Line | | | | | | | 1,541.00 |
| 8031203 | Moil Point | | | | | | | 1,541.00 |
| 8031204 | Conical Point | | | | | | | 1,541.00 |
| * CATERPILLAR H 160 | | | | | | | | |
| 8031300 | Blunt End | 403 | 51" | 6.2990 | | 2 | | 2,185.00 |
| 8031301 | Flat Chisel Cross Cut | | | | | | | 2,185.00 |
| 8031302 | Flat Chisel In Line | | | | | | | 2,185.00 |
| 8031303 | Moil Point | | | | | | | 2,185.00 |
| 8031304 | Conical Point | | | | | | | 2,185.00 |
| * CATERPILLAR H 160C | | | | | | | | |
| 8031500 | Blunt End | | 55" | 6.2160 | | 2 | | 2,343.00 |
| 8031501 | Flat Chisel Cross Cut | | | | | | | 2,343.00 |
| 8031502 | Flat Chisel In Line | | | | | | | 2,343.00 |
| 8031503 | Moil Point | | | | | | | 2,343.00 |
| 8031504 | Conical Point | | | | | | | 2,343.00 |
| CATERPILLAR H 180 | | | | | | | | |
| 8031400 | Blunt End | 511 | 57" | 6.6930 | | 2 | | 3,068.00 |
| 8031401 | Flat Chisel Cross Cut | | | | | | | 3,068.00 |
| 8031402 | Flat Chisel In Line | | | | | | | 3,068.00 |
| 8031403 | Moil Point | | | | | | | 3,068.00 |
| 8031404 | Conical Point | | | | | | | 3,068.00 |
| CHGO PNEU CP 75-80-100H | | | | | | | | |
| 8040100 | Blunt End | 14 | 21 1/2" | 1.7720 | | 2 | | 147.00 |
| 8040101 | Flat Chisel Cross Cut | | | | | | | 147.00 |
| 8040102 | Flat Chisel In Line | | | | | | | 147.00 |
| 8040103 | Moil Point | | | | | | | 147.00 |
| 8040104 | Conical Point | | | | | | | 147.00 |
| CHGO PNEU CP110H | | | | | | | | |
| 8040200 | Blunt End | 14 | 20" | 1.9690 | | 2 | | 149.00 |
| 8040201 | Flat Chisel Cross Cut | | | | | | | 149.00 |
| 8040202 | Flat Chisel In Line | | | | | | | 149.00 |
| 8040203 | Moil Point | | | | | | | 149.00 |
| 8040204 | Conical Point | | | | | | | 149.00 |
| * CHGO PNEU CP180H | | | | | | | | |
| 8040300 | Blunt End | 29 | 23 1/2" | 2.5590 | | 2 | | 238.00 |
| 8040301 | Flat Chisel Cross Cut | | | | | | | 238.00 |
| 8040302 | Flat Chisel In Line | | | | | | | 238.00 |
| 8040303 | Moil Point | | | | | | | 238.00 |
| 8040304 | Conical Point | | | | | | | 238.00 |
| CHGO PNEU CP 250H1 | | | | | | | | |
| 8040400 | Blunt End | 60 | 31 1/2" | 3.1500 | | 2 | 2.1650 | 409.00 |
| 8040401 | Flat Chisel Cross Cut | | | | | | | 409.00 |
| 8040402 | Flat Chisel In Line | | | | | | | 409.00 |
| 8040403 | Moil Point | | | | | | | 409.00 |
| 8040404 | Conical Point | | | | | | | 409.00 |
| CHGO PNEU CP 400H | | | | | | | | |
| 8040500 | Blunt End | 88 | 33" | 3.7400 | | 2 | | 574.00 |
| 8040501 | Flat Chisel Cross Cut | | | | | | | 574.00 |
| 8040502 | Flat Chisel In Line | | | | | | | 574.00 |
| 8040503 | Moil Point | | | | | | | 574.00 |
| 8040504 | Conical Point | | | | | | | 574.00 |
| CHGO PNEU CP 600-700-900H | | | | | | | | |
| 8040600 | Blunt End | 117 | 35 1/2" | 4.1340 | | 2 | | 680.00 |
| 8040601 | Flat Chisel Cross Cut | | | | | | | 680.00 |
| 8040602 | Flat Chisel In Line | | | | | | | 680.00 |
| 8040603 | Moil Point | | | | | | | 680.00 |
| 8040604 | Conical Point | | | | | | | 680.00 |
| AJAX TAMPING PADS - stems sold seperately | | | | | | | | |
| 8000001 | 8"x8" Square Tamping Pad | | | | | | | \$750.00 |
| 8000002 | 12"x12" Square Tamping Pad | | | | | | | \$1,100.00 |

**Note other point styles and lengths available upon request.



DEMOLITION TOOL PRICING

| PART No. | Point Description | WT lbs | O.A.L. | DIA. inch | Collar inch | No. of Slots | Shank Dia. In. | LIST PRICE |
|----------|--|--------|---------|-----------|-------------|--------------|----------------|------------|
| 8040702 | Flat Chisel In Line | | | | | | | 1,066.00 |
| 8040703 | Moil Point | | | | | | | 1,066.00 |
| 8040704 | Conical Point | | | | | | | 1,066.00 |
| | CHGO PNEU CP 1800-2000H | | | | | | | |
| 8040800 | Blunt End | 238 | 43 1/2" | 5.3150 | | 2 | | 1,258.00 |
| 8040801 | Flat Chisel Cross Cut | | | | | | | 1,258.00 |
| 8040802 | Flat Chisel In Line | | | | | | | 1,258.00 |
| 8040803 | Moil Point | | | | | | | 1,258.00 |
| 8040804 | Conical Point | | | | | | | 1,258.00 |
| | * CONSTRUCTION ATTCH CAL-225 | | | | | | | |
| 8300100 | Blunt End | | 19.685 | 1.7710 | | | | 150.00 |
| 8300101 | Flat Chisel Cross Cut | | | | | | | 150.00 |
| 8300102 | Flat Chisel In Line | | | | | | | 150.00 |
| 8300103 | Moil Point | | | | | | | 150.00 |
| 8300104 | Conical Point | | | | | | | 150.00 |
| | * CONSTRUCTION ATTCH CAL-450 | | | | | | | |
| 8300200 | Blunt End | | 23.62 | 2.2440 | | | | 266.00 |
| 8300201 | Flat Chisel Cross Cut | | | | | | | 266.00 |
| 8300202 | Flat Chisel In Line | | | | | | | 266.00 |
| 8300203 | Moil Point | | | | | | | 266.00 |
| 8300204 | Conical Point | | | | | | | 266.00 |
| | * CONSTRUCTION ATTCH CAL-550/750 | | | | | | | |
| 8300300 | Blunt End | | 26.771 | 2.7560 | | | | 272.00 |
| 8300301 | Flat Chisel Cross Cut | | | | | | | 272.00 |
| 8300302 | Flat Chisel In Line | | | | | | | 272.00 |
| 8300303 | Moil Point | | | | | | | 272.00 |
| 8300304 | Conical Point | | | | | | | 272.00 |
| | * CONSTRUCTION ATTCH CAL-1000 | | | | | | | |
| 8300400 | Blunt End | | 37.401 | 3.7400 | | | | 696.00 |
| 8300401 | Flat Chisel Cross Cut | | | | | | | 696.00 |
| 8300402 | Flat Chisel In Line | | | | | | | 696.00 |
| 8300403 | Moil Point | | | | | | | 696.00 |
| 8300404 | Conical Point | | | | | | | 696.00 |
| | * CONSTRUCTION ATTCH CAL-1200 | | | | | | | |
| 8300500 | Blunt End | | 35.433 | 3.543 | | | | 413.00 |
| 8300501 | Flat Chisel Cross Cut | | | | | | | 413.00 |
| 8300502 | Flat Chisel In Line | | | | | | | 413.00 |
| 8300503 | Moil Point | | | | | | | 413.00 |
| 8300504 | Conical Point | | | | | | | 413.00 |
| | * CONSTRUCTION ATTCH CAL-2200 | | | | | | | |
| 8300600 | Blunt End | | 39.37 | 4.1340 | | | | 735.00 |
| 8300601 | Flat Chisel Cross Cut | | | | | | | 735.00 |
| 8300602 | Flat Chisel In Line | | | | | | | 735.00 |
| 8300603 | Moil Point | | | | | | | 735.00 |
| 8300604 | Conical Point | | | | | | | 735.00 |
| | * CONSTRUCTION ATTCH CAL-3200 | | | | | | | |
| 8300700 | Blunt End | | 44.488 | 4.9210 | | | | 1,034.00 |
| 8300701 | Flat Chisel Cross Cut | | | | | | | 1,034.00 |
| 8300702 | Flat Chisel In Line | | | | | | | 1,034.00 |
| 8300703 | Moil Point | | | | | | | 1,034.00 |
| 8300704 | Conical Point | | | | | | | 1,034.00 |
| | * CONSTRUCTION ATTCH CAL-4500 | | | | | | | |
| 8300800 | Blunt End | | 47.244 | 5.3150 | | | | 1,087.00 |
| 8300801 | Flat Chisel Cross Cut | | | | | | | 1,087.00 |
| 8300802 | Flat Chisel In Line | | | | | | | 1,087.00 |
| 8300803 | Moil Point | | | | | | | 1,087.00 |
| 8300804 | Conical Point | | | | | | | 1,087.00 |
| | AJAX TAMPING PADS-stems sold seperately | | | | | | | |
| 8000001 | 8"x8" Square Tamping Pad | | | | | | | \$750.00 |
| 8000002 | 12"x12" Square Tamping Pad | | | | | | | \$1,100.00 |

**Note other point styles and lengths available upon request.



DEMOLITION TOOL PRICING



| PART No. | Point Description | WT lbs | O.A.L. | DIA. inch | Collar inch | No. of Slots | Shank Dia. In. | LIST PRICE |
|--|----------------------------|--------|---------|-----------|-------------|--------------|----------------|------------|
| * CONSTRUCTION ATTCH CAL-6000 | | | | | | | | |
| 8300900 | Blunt End | | 51.181 | 5.5120 | | | | 1,461.00 |
| 8300901 | Flat Chisel Cross Cut | | | | | | | 1,461.00 |
| 8300902 | Flat Chisel In Line | | | | | | | 1,461.00 |
| 8300903 | Moil Point | | | | | | | 1,461.00 |
| 8300904 | Conical Point | | | | | | | 1,461.00 |
| * CONSTRUCTION ATTCH CAL-8000 | | | | | | | | |
| 8301000 | Blunt End | | 53.150 | 5.9050 | | | | 1,501.00 |
| 8301001 | Flat Chisel Cross Cut | | | | | | | 1,501.00 |
| 8301002 | Flat Chisel In Line | | | | | | | 1,501.00 |
| 8301003 | Moil Point | | | | | | | 1,501.00 |
| 8301004 | Conical Point | | | | | | | 1,501.00 |
| * CONSTRUCTION ATTCH CAL-11000 | | | | | | | | |
| 8301100 | Blunt End | | 64.960 | 6.8900 | | | | 2,695.00 |
| 8301101 | Flat Chisel Cross Cut | | | | | | | 2,695.00 |
| 8301102 | Flat Chisel In Line | | | | | | | 2,695.00 |
| 8301103 | Moil Point | | | | | | | 2,695.00 |
| 8301104 | Conical Point | | | | | | | 2,695.00 |
| * ESCO ES14AC | | | | | | | | |
| 8240100 | Blunt End | | 20" | 2.2520 | | 0 | 2.2520 | 183.00 |
| 8240101 | Flat Chisel Cross Cut | | | | | | | 183.00 |
| 8240102 | Flat Chisel In Line | | | | | | | 183.00 |
| 8240103 | Moil Point | | | | | | | 183.00 |
| 8240104 | Conical Point | | | | | | | 183.00 |
| * ESCO ES14DF | | | | | | | | |
| 8240200 | Blunt End | | 20" | 2.2520 | | 0 | 2.2520 | 183.00 |
| 8240201 | Flat Chisel Cross Cut | | | | | | | 183.00 |
| 8240202 | Flat Chisel In Line | | | | | | | 183.00 |
| 8240203 | Moil Point | | | | | | | 183.00 |
| 8240204 | Conical Point | | | | | | | 183.00 |
| GEHL YC 70 | | | | | | | | |
| 8070100 | Blunt End | 11 | 19" | 1.7720 | | 1 | 1.3780 | 120.00 |
| 8070101 | Flat Chisel Cross Cut | | | | | | | 120.00 |
| 8070102 | Flat Chisel In Line | | | | | | | 120.00 |
| 8070103 | Moil Point | | | | | | | 120.00 |
| 8070104 | Conical Point | | | | | | | 120.00 |
| * HUSKIE HH100 | | | | | | | | |
| 8080000 | Blunt End | 9 | 15 1/2" | 1.5750 | | 1 | 1.2600 | 86.00 |
| 8080001 | Flat Chisel Cross Cut | | | | | | | 86.00 |
| 8080002 | Flat Chisel In Line | | | | | | | 86.00 |
| 8080003 | Moil Point | | | | | | | 86.00 |
| 8080004 | Conical Point | | | | | | | 86.00 |
| * HUSKIE HH 150/HH 150-2 | | | | | | | | |
| 8080100 | Blunt End | 13 | 20" | 1.9690 | | 1 | 1.5750 | 141.00 |
| 8080101 | Flat Chisel Cross Cut | | | | | | | 141.00 |
| 8080102 | Flat Chisel In Line | | | | | | | 141.00 |
| 8080103 | Moil Point | | | | | | | 141.00 |
| 8080104 | Conical Point | | | | | | | 141.00 |
| * HUSKIE HH 300/HH 300-2 | | | | | | | | |
| 8080200 | Blunt End | 20 | 23 5/8" | 2.3620 | | 1 | 1.9690 | 199.00 |
| 8080201 | Flat Chisel Cross Cut | | | | | | | 199.00 |
| 8080202 | Flat Chisel In Line | | | | | | | 199.00 |
| 8080203 | Moil Point | | | | | | | 199.00 |
| 8080204 | Conical Point | | | | | | | 199.00 |
| * HUSKIE HH 500 | | | | | | | | |
| 8080300 | Blunt End | 26 | 24" | 2.5500 | | 1 | 1.9690 | 247.00 |
| 8080301 | Flat Chisel Cross Cut | | | | | | | 247.00 |
| 8080302 | Flat Chisel In Line | | | | | | | 247.00 |
| 8080303 | Moil Point | | | | | | | 247.00 |
| 8080304 | Conical Point | | | | | | | 247.00 |
| AJAX TAMPING PADS-stems sold seperately | | | | | | | | |
| 8000001 | 8"x8" Square Tamping Pad | | | | | | | \$750.00 |
| 8000002 | 12"x12" Square Tamping Pad | | | | | | | \$1,100.00 |

**Note other point styles and lengths available upon request.



DEMOLITION TOOL PRICING

| PART No. | Point Description | WT lbs | O.A.L. | DIA. inch | Collar inch | No. of Slots | Shank Dia. In. | LIST PRICE |
|--|----------------------------|--|---------|-----------|-------------|--------------|----------------|------------|
| * HUSKIE HH 500-2 | | New Style 500, missing a second pilot diameter | | | | | | |
| 8081300 | Blunt End | 26 | 24" | 2.5500 | | 1 | 1.9690 | 247.00 |
| 8081301 | Flat Chisel Cross Cut | | | | | | | 247.00 |
| 8081302 | Flat Chisel In Line | | | | | | | 247.00 |
| 8081303 | Moil Point | | | | | | | 247.00 |
| 8081304 | Conical Point | | | | | | | 247.00 |
| * HUSKIE HH 750/HH 750-2 | | | | | | | | |
| 8080400 | Blunt End | 46 | 29 1/2" | 2.9530 | | 1 | 2.4410 | 365.00 |
| 8080401 | Flat Chisel Cross Cut | | | | | | | 365.00 |
| 8080402 | Flat Chisel In Line | | | | | | | 365.00 |
| 8080403 | Moil Point | | | | | | | 365.00 |
| 8080404 | Conical Point | | | | | | | 365.00 |
| * HUSKIE HH 1000/HH 1000-2 | | | | | | | | |
| 8080500 | Blunt End | 84 | 35" | 3.5430 | | 1 | 2.8350 | 579.00 |
| 8080501 | Flat Chisel Cross Cut | | | | | | | 579.00 |
| 8080502 | Flat Chisel In Line | | | | | | | 579.00 |
| 8080503 | Moil Point | | | | | | | 579.00 |
| 8080504 | Conical Point | | | | | | | 579.00 |
| * HUSKIE HH 2000 | | | | | | | | |
| 8080600 | Blunt End | 165 | 39 3/8" | 4.5280 | | 1 | 3.8580 | 1,024.00 |
| 8080601 | Flat Chisel Cross Cut | | | | | | | 1,024.00 |
| 8080602 | Flat Chisel In Line | | | | | | | 1,024.00 |
| 8080603 | Moil Point | | | | | | | 1,024.00 |
| 8080604 | Conical Point | | | | | | | 1,024.00 |
| * HUSKIE HH 3600 | | | | | | | | |
| 8080700 | Blunt End | 260 | 45 1/4" | 5.3150 | | 1 | 4.6460 | 1,670.00 |
| 8080701 | Flat Chisel Cross Cut | | | | | | | 1,670.00 |
| 8080702 | Flat Chisel In Line | | | | | | | 1,670.00 |
| 8080703 | Moil Point | | | | | | | 1,670.00 |
| 8080704 | Conical Point | | | | | | | 1,670.00 |
| * HUSKIE HH 4500 | | | | | | | | |
| 8080800 | Blunt End | 340 | 49 1/4" | 5.7090 | | 1 | 4.9210 | 2,318.00 |
| 8080801 | Flat Chisel Cross Cut | | | | | | | 2,318.00 |
| 8080802 | Flat Chisel In Line | | | | | | | 2,318.00 |
| 8080803 | Moil Point | | | | | | | 2,318.00 |
| 8080804 | Conical Point | | | | | | | 2,318.00 |
| * HUSKIE HH 5800 | | | | | | | | |
| 8080900 | Blunt End | 386 | 53" | 6.1020 | | 1 | 5.3540 | 2,583.00 |
| 8080901 | Flat Chisel Cross Cut | | | | | | | 2,583.00 |
| 8080902 | Flat Chisel In Line | | | | | | | 2,583.00 |
| 8080903 | Moil Point | | | | | | | 2,583.00 |
| 8080904 | Conical Point | | | | | | | 2,583.00 |
| * INDECO HB 5/MES451/462/521/550 | | | | | | | | |
| 8100400 | Blunt End | 31 | 27 1/2" | 2.5590 | | 2 | | 276.00 |
| 8100401 | Flat Chisel Cross Cut | | | | | | | 276.00 |
| 8100402 | Flat Chisel In Line | | | | | | | 276.00 |
| 8100403 | Moil Point | | | | | | | 276.00 |
| 8100404 | Conical Point | | | | | | | 276.00 |
| * INDECO HB 8 | | | | | | | | |
| 8100700 | Blunt End | 51 | 27 1/2" | 3.1500 | | 2 | | 392.00 |
| 8100701 | Flat Chisel Cross Cut | | | | | | | 392.00 |
| 8100702 | Flat Chisel In Line | | | | | | | 392.00 |
| 8100703 | Moil Point | | | | | | | 392.00 |
| 8100704 | Conical Point | | | | | | | 392.00 |
| * INDECO HB 12/MES 1200 | | | | | | | | |
| 8100800 | Blunt End | 75 | 31 1/2" | 3.5430 | | 2 | | 559.00 |
| 8100801 | Flat Chisel Cross Cut | | | | | | | 559.00 |
| 8100802 | Flat Chisel In Line | | | | | | | 559.00 |
| 8100803 | Moil Point | | | | | | | 559.00 |
| 8100804 | Conical Point | | | | | | | 559.00 |
| AJAX TAMPING PADS - stems sold seperately | | | | | | | | |
| 8000001 | 8"x8" Square Tamping Pad | | | | | | | \$750.00 |
| 8000002 | 12"x12" Square Tamping Pad | | | | | | | \$1,100.00 |

**Note other point styles and lengths available upon request.



DEMOLITION TOOL PRICING



| PART No. | Point Description | WT lbs | O.A.L. | DIA. inch | Collar inch | No. of Slots | Shank Dia. In. | LIST PRICE |
|--|----------------------------|--------|---------|-----------|-------------|--------------|----------------|------------|
| * INDECO HB 19 | | | | | | | | |
| 8100900 | Blunt End | 132 | 38" | 4.2910 | | 2 | | 915.00 |
| 8100901 | Flat Chisel Cross Cut | | | | | | | 915.00 |
| 8100902 | Flat Chisel In Line | | | | | | | 915.00 |
| 8100903 | Moil Point | | | | | | | 915.00 |
| 8100904 | Conical Point | | | | | | | 915.00 |
| * INDECO HB 27/MES2000 | | | | | | | | |
| 8101100 | Blunt End | 190 | 43 1/2" | 4.6850 | | 2 | | 1,165.00 |
| 8101101 | Flat Chisel Cross Cut | | | | | | | 1,165.00 |
| 8101102 | Flat Chisel In Line | | | | | | | 1,165.00 |
| 8101103 | Moil Point | | | | | | | 1,165.00 |
| 8101104 | Conical Point | | | | | | | 1,165.00 |
| * INDECO MES121/150 | | | | | | | | |
| 8100100 | Blunt End | 11 | 19 1/2" | 1.7720 | | 2 | | 142.00 |
| 8100101 | Flat Chisel Cross Cut | | | | | | | 142.00 |
| 8100102 | Flat Chisel In Line | | | | | | | 142.00 |
| 8100103 | Moil Point | | | | | | | 142.00 |
| 8100104 | Conical Point | | | | | | | 142.00 |
| * INDECO MES180/181/200 | | | | | | | | |
| 8100200 | Blunt End | 13 | 22 1/2" | 1.8900 | | 2 | | 175.00 |
| 8100201 | Flat Chisel Cross Cut | | | | | | | 175.00 |
| 8100202 | Flat Chisel In Line | | | | | | | 175.00 |
| 8100203 | Moil Point | | | | | | | 175.00 |
| 8100204 | Conical Point | | | | | | | 175.00 |
| * INDECO MES300/301/350/351 | | | | | | | | |
| 8100300 | Blunt End | 21 | 23 1/2" | 2.1650 | | 2 | | 203.00 |
| 8100301 | Flat Chisel Cross Cut | | | | | | | 203.00 |
| 8100302 | Flat Chisel In Line | | | | | | | 203.00 |
| 8100303 | Moil Point | | | | | | | 203.00 |
| 8100304 | Conical Point | | | | | | | 203.00 |
| * INDECO MES 553/523 | | | | | | | | |
| 8100500 | Blunt End | 46 | 28 1/2" | 2.8740 | | 2 | | 358.00 |
| 8100501 | Flat Chisel Cross Cut | | | | | | | 358.00 |
| 8100502 | Flat Chisel In Line | | | | | | | 358.00 |
| 8100503 | Moil Point | | | | | | | 358.00 |
| 8100504 | Conical Point | | | | | | | 358.00 |
| * INDECO MES 621/650 | | | | | | | | |
| 8100600 | Blunt End | 49 | 27 1/2" | 3.1500 | | 2 | | 392.00 |
| 8100601 | Flat Chisel Cross Cut | | | | | | | 392.00 |
| 8100602 | Flat Chisel In Line | | | | | | | 392.00 |
| 8100603 | Moil Point | | | | | | | 392.00 |
| 8100604 | Conical Point | | | | | | | 392.00 |
| * INDECO MES 900/1000 | | | | | | | | |
| 8102000 | Blunt End | | 27 1/2" | 3.3010 | | 2 | | 482.00 |
| 8102001 | Flat Chisel Cross Cut | | | | | | | 482.00 |
| 8102002 | Flat Chisel In Line | | | | | | | 482.00 |
| 8102003 | Moil Point | | | | | | | 482.00 |
| 8102004 | Conical Point | | | | | | | 482.00 |
| * INDECO MES 1500 | | | | | | | | |
| 8102100 | Blunt End | | 38" | 4.2910 | | 2 | | 915.00 |
| 8102101 | Flat Chisel Cross Cut | | | | | | | 915.00 |
| 8102102 | Flat Chisel In Line | | | | | | | 915.00 |
| 8102103 | Moil Point | | | | | | | 915.00 |
| 8102104 | Conical Point | | | | | | | 915.00 |
| * INDECO MES 1800/1750 | | | | | | | | |
| 8101000 | Blunt End | 159 | 39 1/2" | 4.4880 | | 2 | | 968.00 |
| 8101001 | Flat Chisel Cross Cut | | | | | | | 968.00 |
| 8101002 | Flat Chisel In Line | | | | | | | 968.00 |
| 8101003 | Moil Point | | | | | | | 968.00 |
| 8101004 | Conical Point | | | | | | | 968.00 |
| AJAX TAMPING PADS - stems sold seperately | | | | | | | | |
| 8000001 | 8"x8" Square Tamping Pad | | | | | | | \$750.00 |
| 8000002 | 12"x12" Square Tamping Pad | | | | | | | \$1,100.00 |

**Note other point styles and lengths available upon request.



DEMOLITION TOOL PRICING

| PART No. | Point Description | WT lbs | O.A.L. | DIA. inch | Collar inch | No. of Slots | Shank Dia. In. | LIST PRICE |
|--|----------------------------|--------|---------|-----------|-------------|--------------|----------------|------------|
| * INDECO MES 2000 | | | | | | | | |
| 8101100 | Blunt End | 223 | 39 1/2" | 4.6450 | | 2 | | 1,165.00 |
| 8101101 | Flat Chisel Cross Cut | | | | | | | 1,165.00 |
| 8101102 | Flat Chisel In Line | | | | | | | 1,165.00 |
| 8101103 | Moil Point | | | | | | | 1,165.00 |
| 8101104 | Conical Point | | | | | | | 1,165.00 |
| * INDECO MES 2500 | | | | | | | | |
| 8101200 | Blunt End | 223 | 44 1/2" | 5.1180 | | 2 | | 1,341.00 |
| 8101201 | Flat Chisel Cross Cut | | | | | | | 1,341.00 |
| 8101202 | Flat Chisel In Line | | | | | | | 1,341.00 |
| 8101203 | Moil Point | | | | | | | 1,341.00 |
| 8101204 | Conical Point | | | | | | | 1,341.00 |
| * INDECO MES 3000 | | | | | | | | |
| 8101300 | Blunt End | 287 | 47" | 5.5120 | | 2 | | 1,552.00 |
| 8101301 | Flat Chisel Cross Cut | | | | | | | 1,552.00 |
| 8101302 | Flat Chisel In Line | | | | | | | 1,552.00 |
| 8101303 | Moil Point | | | | | | | 1,552.00 |
| 8101304 | Conical Point | | | | | | | 1,552.00 |
| * INDECO MES 3500 | | | | | | | | |
| 8101400 | Blunt End | 337 | 52" | 5.6690 | | 2 | | 1,872.00 |
| 8101401 | Flat Chisel Cross Cut | | | | | | | 1,872.00 |
| 8101402 | Flat Chisel In Line | | | | | | | 1,872.00 |
| 8101403 | Moil Point | | | | | | | 1,872.00 |
| 8101404 | Conical Point | | | | | | | 1,872.00 |
| * INDECO MES 4000/4001 | | | | | | | | |
| 8101900 | Blunt End | | 49 1/2" | 5.8890 | | 2 | | 1,939.00 |
| 8101901 | Flat Chisel Cross Cut | | | | | | | 1,939.00 |
| 8101902 | Flat Chisel In Line | | | | | | | 1,939.00 |
| 8101903 | Moil Point | | | | | | | 1,939.00 |
| 8101904 | Conical Point | | | | | | | 1,939.00 |
| * INDECO MES 5000 | | | | | | | | |
| 8101500 | Blunt End | 401 | 52" | 6.2990 | | 2 | | 2,201.00 |
| 8101501 | Flat Chisel Cross Cut | | | | | | | 2,201.00 |
| 8101502 | Flat Chisel In Line | | | | | | | 2,201.00 |
| 8101503 | Moil Point | | | | | | | 2,201.00 |
| 8101504 | Conical Point | | | | | | | 2,201.00 |
| * INDECO MES 7000 | | | | | | | | |
| 8101600 | Blunt End | 595 | 59" | 7.0870 | | 2 | | 3,449.00 |
| 8101601 | Flat Chisel Cross Cut | | | | | | | 3,449.00 |
| 8101602 | Flat Chisel In Line | | | | | | | 3,449.00 |
| 8101603 | Moil Point | | | | | | | 3,449.00 |
| 8101604 | Conical Point | | | | | | | 3,449.00 |
| * INDECO MES 8500 | | | | | | | | |
| 8101700 | Blunt End | 765 | 60-1/4" | 7.677 | | 2 | 6.122 | 3,916.00 |
| 8101701 | Flat Chisel Cross Cut | | | | | | | 3,916.00 |
| 8101702 | Flat Chisel In Line | | | | | | | 3,916.00 |
| 8101703 | Moil Point | | | | | | | 3,916.00 |
| 8101704 | Conical Point | | | | | | | 3,916.00 |
| * INDECO MES 12000 | | | | | | | | |
| 8101800 | Blunt End | 1000 | 62-1/4" | 8.464 | | 2 | 6.496 | 6,017.00 |
| 8101801 | Flat Chisel Cross Cut | | | | | | | 6,017.00 |
| 8101802 | Flat Chisel In Line | | | | | | | 6,017.00 |
| 8101803 | Moil Point | | | | | | | 6,017.00 |
| 8101804 | Conical Point | | | | | | | 6,017.00 |
| JCB HM 160 | | | | | | | | |
| 8120100 | Blunt End | 11 | 19" | 1.7720 | | 1 | | 112.00 |
| 8120101 | Flat Chisel Cross Cut | | | | | | | 112.00 |
| 8120102 | Flat Chisel In Line | | | | | | | 112.00 |
| 8120103 | Moil Point | | | | | | | 112.00 |
| 8120104 | Conical Point | | | | | | | 112.00 |
| AJAX TAMPING PADS - stems sold seperately | | | | | | | | |
| 8000001 | 8"x8" Square Tamping Pad | | | | | | | \$750.00 |
| 8000002 | 12"x12" Square Tamping Pad | | | | | | | \$1,100.00 |

**Note other point styles and lengths available upon request.



DEMOLITION TOOL PRICING



| PART No. | Point Description | WT lbs | O.A.L. | DIA. inch | Collar inch | No. of Slots | Shank Dia. In. | LIST PRICE |
|---|----------------------------|--------------------|---------|-----------|-------------|--------------|----------------|------------|
| * JCB HM 260 | | SAME AS CAT H 63 | | | | | | |
| 8120200 | Blunt End | 33 | 27 1/2" | 2.4800 | | 1 | | 271.00 |
| 8120201 | Flat Chisel Cross Cut | | | | | | | 271.00 |
| 8120202 | Flat Chisel In Line | | | | | | | 271.00 |
| 8120203 | Moil Point | | | | | | | 271.00 |
| 8120204 | Conical Point | | | | | | | 271.00 |
| * JCB HM 360 | | SAME AS RAMMER S25 | | | | | | |
| 8120300 | Blunt End | 42 | 29" | 2.7560 | | 2 | | 328.00 |
| 8120301 | Flat Chisel Cross Cut | | | | | | | 328.00 |
| 8120302 | Flat Chisel In Line | | | | | | | 328.00 |
| 8120303 | Moil Point | | | | | | | 328.00 |
| 8120304 | Conical Point | | | | | | | 328.00 |
| * KENT HB 2.5G / HB 3R | | | | | | | | |
| 8130400 | Blunt End | | | 2.0470 | | 1 | 2.0080 | 165.00 |
| 8130401 | Flat Chisel Cross Cut | | | | | | | 165.00 |
| 8130402 | Flat Chisel In Line | | | | | | | 165.00 |
| 8130403 | Moil Point | | | | | | | 165.00 |
| 8130404 | Conical Point | | | | | | | 165.00 |
| * KENT HB 05R | | | | | | | | |
| 8130100 | Blunt End | | | 1.1810 | | 1 | | 60.00 |
| 8130101 | Flat Chisel Cross Cut | | | | | | | 60.00 |
| 8130102 | Flat Chisel In Line | | | | | | | 60.00 |
| 8130103 | Moil Point | | | | | | | 60.00 |
| 8130104 | Conical Point | | | | | | | 60.00 |
| * KENT KB 555 | | | | | | | | |
| 8132600 | Blunt End | | 30" | 2.5000 | | 1 | | 277.00 |
| 8132601 | Flat Chisel Cross Cut | | | | | | | 277.00 |
| 8132602 | Flat Chisel In Line | | | | | | | 277.00 |
| 8132603 | Moil Point | | | | | | | 277.00 |
| 8132604 | Conical Point | | | | | | | 277.00 |
| * KENT KB 555 HD | | | | | | | | |
| 8132700 | Blunt End | | 30" | 3.0000 | | 1 | | 391.00 |
| 8132701 | Flat Chisel Cross Cut | | | | | | | 391.00 |
| 8132702 | Flat Chisel In Line | | | | | | | 391.00 |
| 8132703 | Moil Point | | | | | | | 391.00 |
| 8132704 | Conical Point | | | | | | | 391.00 |
| * KENT KB 999 | | | | | | | | |
| 8132800 | Blunt End | 78 | 29" | 3.4800 | | 1 | | 453.00 |
| 8132801 | Flat Chisel Cross Cut | | | | | | | 453.00 |
| 8132802 | Flat Chisel In Line | | | | | | | 453.00 |
| 8132803 | Moil Point | | | | | | | 453.00 |
| 8132804 | Conical Point | | | | | | | 453.00 |
| * KENT KF4/F4 | | | | | | | | |
| 8132900 | Blunt End | 20 | 21 1/2" | 2.3620 | | 1 | | 180.00 |
| 8132901 | Flat Chisel Cross Cut | | | | | | | 180.00 |
| 8132902 | Flat Chisel In Line | | | | | | | 180.00 |
| 8132903 | Moil Point | | | | | | | 180.00 |
| 8132904 | Conical Point | | | | | | | 180.00 |
| * KENT KF5/F5 | | | | | | | | |
| 8130800 | Blunt End | 35 | 24" | 2.6380 | | 1 | | 313.00 |
| 8130801 | Flat Chisel Cross Cut | | | | | | | 313.00 |
| 8130802 | Flat Chisel In Line | | | | | | | 313.00 |
| 8130803 | Moil Point | | | | | | | 313.00 |
| 8130804 | Conical Point | | | | | | | 313.00 |
| * KENT KF6/F6 | | | | | | | | |
| 8131000 | Blunt End | 44 | 28 1/2" | 2.9130 | | 2 | 2.1650 | 380.00 |
| 8131001 | Flat Chisel Cross Cut | | | | | | | 380.00 |
| 8131002 | Flat Chisel In Line | | | | | | | 380.00 |
| 8131003 | Moil Point | | | | | | | 380.00 |
| 8131004 | Conical Point | | | | | | | 380.00 |
| AJAX TAMPING PADS - stems sold seperately | | | | | | | | |
| 8000001 | 8"x8" Square Tamping Pad | | | | | | | \$750.00 |
| 8000002 | 12"x12" Square Tamping Pad | | | | | | | \$1,100.00 |

**Note other point styles and lengths available upon request.



DEMOLITION TOOL PRICING

| PART No. | Point Description | WT lbs | O.A.L. | DIA. inch | Collar inch | No. of Slots | Shank Dia. In. | LIST PRICE |
|--|----------------------------|--------|---------|-----------|-------------|--------------|----------------|------------|
| * KENT KF9/F9 | | | | | | | | |
| 8131200 | Blunt End | 73 | 31 1/2" | 3.5430 | | 2 | 2.7560 | 517.00 |
| 8131201 | Flat Chisel Cross Cut | | | | | | | 517.00 |
| 8131202 | Flat Chisel In Line | | | | | | | 517.00 |
| 8131203 | Moil Point | | | | | | | 517.00 |
| 8131204 | Conical Point | | | | | | | 517.00 |
| * KENT KF12/F12 | | | | | | | | |
| 8131700 | Blunt End | 146 | 43 1/2" | 4.1220 | | 2 | 2.9910 | 848.00 |
| 8131701 | Flat Chisel Cross Cut | | | | | | | 848.00 |
| 8131702 | Flat Chisel In Line | | | | | | | 848.00 |
| 8131703 | Moil Point | | | | | | | 848.00 |
| 8131704 | Conical Point | | | | | | | 848.00 |
| * KENT KF19/F19 | | | | | | | | |
| 8131800 | Blunt End | 190 | 43 1/2" | 4.7240 | | 2 | 3.5430 | 1,100.00 |
| 8131801 | Flat Chisel Cross Cut | | | | | | | 1,100.00 |
| 8131802 | Flat Chisel In Line | | | | | | | 1,100.00 |
| 8131803 | Moil Point | | | | | | | 1,100.00 |
| 8131804 | Conical Point | | | | | | | 1,100.00 |
| * KENT KF22/F22 | | | | | | | | |
| 8132000 | Blunt End | 258 | 47" | 5.3150 | | 2 | 4.1430 | 1,412.00 |
| 8132001 | Flat Chisel Cross Cut | | | | | | | 1,412.00 |
| 8132002 | Flat Chisel In Line | | | | | | | 1,412.00 |
| 8132003 | Moil Point | | | | | | | 1,412.00 |
| 8132004 | Conical Point | | | | | | | 1,412.00 |
| * KENT KF27G | | | | | | | | |
| 8130600 | Blunt End | | 52" | 5.4880 | | 2 | 4.3050 | 1,722.00 |
| 8130601 | Flat Chisel Cross Cut | | | | | | | 1,722.00 |
| 8130602 | Flat Chisel In Line | | | | | | | 1,722.00 |
| 8130603 | Moil Point | | | | | | | 1,722.00 |
| 8130604 | Conical Point | | | | | | | 1,722.00 |
| * KENT KF45/F45 | | | | | | | | |
| 8132400 | Blunt End | 525 | 57" | 6.4630 | | 2 | 5.1050 | 2,796.00 |
| 8132401 | Flat Chisel Cross Cut | | | | | | | 2,796.00 |
| 8132402 | Flat Chisel In Line | | | | | | | 2,796.00 |
| 8132403 | Moil Point | | | | | | | 2,796.00 |
| 8132404 | Conical Point | | | | | | | 2,796.00 |
| * KENT KHB 3G 11 | | | | | | | | |
| 8130700 | Blunt End | 20 | 22" | 2.3620 | | 1 | | 180.00 |
| 8130701 | Flat Chisel Cross Cut | | | | | | | 180.00 |
| 8130702 | Flat Chisel In Line | | | | | | | 180.00 |
| 8130703 | Moil Point | | | | | | | 180.00 |
| 8130704 | Conical Point | | | | | | | 180.00 |
| * KENT KHB 5G 11 | | | | | | | | |
| 8131100 | Blunt End | 46 | 28 1/2" | 2.9530 | | 2 | | 357.00 |
| 8131101 | Flat Chisel Cross Cut | | | | | | | 357.00 |
| 8131102 | Flat Chisel In Line | | | | | | | 357.00 |
| 8131103 | Moil Point | | | | | | | 357.00 |
| 8131104 | Conical Point | | | | | | | 357.00 |
| * KENT KHB 8G 11 | | | | | | | | |
| 8131300 | Blunt End | 75 | 29" | 3.5430 | | 2 | | 499.00 |
| 8131301 | Flat Chisel Cross Cut | | | | | | | 499.00 |
| 8131302 | Flat Chisel In Line | | | | | | | 499.00 |
| 8131303 | Moil Point | | | | | | | 499.00 |
| 8131304 | Conical Point | | | | | | | 499.00 |
| * KENT KHB 10G 11/HD | | | | | | | | |
| 8131600 | Blunt End | 119 | 38" | 4.1170 | | 2 | | 751.00 |
| 8131601 | Flat Chisel Cross Cut | | | | | | | 751.00 |
| 8131602 | Flat Chisel In Line | | | | | | | 751.00 |
| 8131603 | Moil Point | | | | | | | 751.00 |
| 8131604 | Conical Point | | | | | | | 751.00 |
| AJAX TAMPING PADS - stems sold seperately | | | | | | | | |
| 8000001 | 8"x8" Square Tamping Pad | | | | | | | \$750.00 |
| 8000002 | 12"x12" Square Tamping Pad | | | | | | | \$1,100.00 |

**Note other point styles and lengths available upon request.



DEMOLITION TOOL PRICING



| PART No. | Point Description | WT lbs | O.A.L. | DIA. inch | Collar inch | No. of Slots | Shank Dia. In. | LIST PRICE |
|--|----------------------------|--------|---------|-----------|-------------|--------------|----------------|------------|
| * KENT KHB 15G 11 | | | | | | | | |
| 8131900 | Blunt End | 172 | 39 1/2" | 4.7240 | | 2 | | 992.00 |
| 8131901 | Flat Chisel Cross Cut | | | | | | | 992.00 |
| 8131902 | Flat Chisel In Line | | | | | | | 992.00 |
| 8131903 | Moil Point | | | | | | | 992.00 |
| 8131904 | Conical Point | | | | | | | 992.00 |
| * KENT KHB 20G 11 | | | | | | | | |
| 8132100 | Blunt End | 260 | 47" | 5.3150 | | 2 | | 1,385.00 |
| 8132101 | Flat Chisel Cross Cut | | | | | | | 1,385.00 |
| 8132102 | Flat Chisel In Line | | | | | | | 1,385.00 |
| 8132103 | Moil Point | | | | | | | 1,385.00 |
| 8132104 | Conical Point | | | | | | | 1,385.00 |
| * KENT KHB 30G 11 | | | | | | | | |
| 8132200 | Blunt End | 346 | 51" | 5.9060 | | 2 | | 1,879.00 |
| 8132201 | Flat Chisel Cross Cut | | | | | | | 1,879.00 |
| 8132202 | Flat Chisel In Line | | | | | | | 1,879.00 |
| 8132203 | Moil Point | | | | | | | 1,879.00 |
| 8132204 | Conical Point | | | | | | | 1,879.00 |
| * KENT KHB 40G 11 | | | | | | | | |
| 8132300 | Blunt End | 403 | 51" | 6.2700 | | 2 | | 2,185.00 |
| 8132301 | Flat Chisel Cross Cut | | | | | | | 2,185.00 |
| 8132302 | Flat Chisel In Line | | | | | | | 2,185.00 |
| 8132303 | Moil Point | | | | | | | 2,185.00 |
| 8132304 | Conical Point | | | | | | | 2,185.00 |
| KENT KHB 50G 11 | | | | | | | | |
| 8132500 | Blunt End | 595 | 59" | 7.0870 | | 2 | | 3,449.00 |
| 8132501 | Flat Chisel Cross Cut | | | | | | | 3,449.00 |
| 8132502 | Flat Chisel In Line | | | | | | | 3,449.00 |
| 8132503 | Moil Point | | | | | | | 3,449.00 |
| 8132504 | Conical Point | | | | | | | 3,449.00 |
| KENT KHB 400 | | | | | | | | |
| 8131400 | Blunt End | 88 | 33" | 3.7400 | | 1 | | 591.00 |
| 8131401 | Flat Chisel Cross Cut | | | | | | | 591.00 |
| 8131402 | Flat Chisel In Line | | | | | | | 591.00 |
| 8131403 | Moil Point | | | | | | | 591.00 |
| 8131404 | Conical Point | | | | | | | 591.00 |
| KUBOTA KXB 300 | | | | | | | | |
| 8140100 | Blunt End | 8 | 16" | 1.5750 | | 2 | | 124.00 |
| 8140101 | Flat Chisel Cross Cut | | | | | | | 124.00 |
| 8140102 | Flat Chisel In Line | | | | | | | 124.00 |
| 8140103 | Moil Point | | | | | | | 124.00 |
| 8140104 | Conical Point | | | | | | | 124.00 |
| KUBOTA KXB 400 | | | | | | | | |
| 8140200 | Blunt End | 11 | 19" | 1.7720 | | 1 | | 112.00 |
| 8140201 | Flat Chisel Cross Cut | | | | | | | 112.00 |
| 8140202 | Flat Chisel In Line | | | | | | | 112.00 |
| 8140203 | Moil Point | | | | | | | 112.00 |
| 8140204 | Conical Point | | | | | | | 112.00 |
| KUBOTA KXB 450 | | | | | | | | |
| 8140300 | Blunt End | 15 | 20" | 1.9690 | | 2 | | 147.00 |
| 8140301 | Flat Chisel Cross Cut | | | | | | | 147.00 |
| 8140302 | Flat Chisel In Line | | | | | | | 147.00 |
| 8140303 | Moil Point | | | | | | | 147.00 |
| 8140304 | Conical Point | | | | | | | 147.00 |
| KUBOTA KXB 500 | | | | | | | | |
| 8140400 | Blunt End | 33 | 27 1/2" | 2.4800 | | 1 | | 271.00 |
| 8140401 | Flat Chisel Cross Cut | | | | | | | 271.00 |
| 8140402 | Flat Chisel In Line | | | | | | | 271.00 |
| 8140403 | Moil Point | | | | | | | 271.00 |
| 8140404 | Conical Point | | | | | | | 271.00 |
| AJAX TAMPING PADS - stems sold seperately | | | | | | | | |
| 8000001 | 8"x8" Square Tamping Pad | | | | | | | \$750.00 |
| 8000002 | 12"x12" Square Tamping Pad | | | | | | | \$1,100.00 |

**Note other point styles and lengths available upon request.



DEMOLITION TOOL PRICING

| PART No. | Point Description | WT lbs | O.A.L. | DIA. inch | Collar inch | No. of Slots | Shank Dia. In. | LIST PRICE |
|----------|--|--------|---------|-----------|-------------|--------------|----------------|------------|
| | KUBOTA KXB 600 | | | | | | | |
| 8140500 | Blunt End | 42 | 29" | 2.7560 | | 2 | | 318.00 |
| 8140501 | Flat Chisel Cross Cut | | | | | | | 318.00 |
| 8140502 | Flat Chisel In Line | | | | | | | 318.00 |
| 8140503 | Moil Point | | | | | | | 318.00 |
| 8140504 | Conical Point | | | | | | | 318.00 |
| | * NPK E-204 | | | | | | | |
| 8163100 | Blunt End | 57 | 31 1/2" | 2.9920 | | 1 | 2.2050 | 409.00 |
| 8163101 | Flat Chisel Cross Cut | | | | | | | 409.00 |
| 8163102 | Flat Chisel In Line | | | | | | | 409.00 |
| 8163103 | Moil Point | | | | | | | 409.00 |
| 8163104 | Conical Point | | | | | | | 409.00 |
| | * NPK E-205 | | | | | | | |
| 8163200 | Blunt End | 80 | 35" | 3.3740 | | 1 | 2.5200 | 553.00 |
| 8163201 | Flat Chisel Cross Cut | | | | | | | 553.00 |
| 8163202 | Flat Chisel In Line | | | | | | | 553.00 |
| 8163203 | Moil Point | | | | | | | 553.00 |
| 8163204 | Conical Point | | | | | | | 553.00 |
| | * NPK E-207 | | | | | | | |
| 8162800 | Blunt End | | 50 3/8" | 4.1730 | | 1 | 3.1490 | 867.00 |
| 8162801 | Flat Chisel Cross Cut | | | | | | | 867.00 |
| 8162802 | Flat Chisel In Line | | | | | | | 867.00 |
| 8162803 | Moil Point | | | | | | | 867.00 |
| 8162804 | Conical Point | | | | | | | 867.00 |
| | * NPK E-208 | | | | | | | |
| 8163300 | Blunt End | | 41 1/2" | 4.5510 | | 1 | 3.3850 | 1,066.00 |
| 8163301 | Flat Chisel Cross Cut | | | | | | | 1,066.00 |
| 8163302 | Flat Chisel In Line | | | | | | | 1,066.00 |
| 8163303 | Moil Point | | | | | | | 1,066.00 |
| 8163304 | Conical Point | | | | | | | 1,066.00 |
| | * NPK E-213 | | | | | | | |
| 8161800 | Blunt End | 258 | 43 1/2" | 5.3540 | | 1 | 3.8580 | 1,458.00 |
| 8161801 | Flat Chisel Cross Cut | | | | | | | 1,458.00 |
| 8161802 | Flat Chisel In Line | | | | | | | 1,458.00 |
| 8161803 | Moil Point | | | | | | | 1,458.00 |
| 8161804 | Conical Point | | | | | | | 1,458.00 |
| | * NPK E216 | | | | | | | |
| 8162700 | Blunt End | | 51" | 5.7180 | | 1 | 4.1640 | 1,869.00 |
| 8162701 | Flat Chisel Cross Cut | | | | | | | 1,869.00 |
| 8162702 | Flat Chisel In Line | | | | | | | 1,869.00 |
| 8162703 | Moil Point | | | | | | | 1,869.00 |
| 8162704 | Conical Point | | | | | | | 1,869.00 |
| | * NPK E218 | | | | | | | |
| 8163500 | Blunt End | | 48" | 5.7280 | | 2 | 4.0150 | 1,599.00 |
| 8163501 | Flat Chisel Cross Cut | | | | | | | 1,599.00 |
| 8163502 | Flat Chisel In Line | | | | | | | 1,599.00 |
| 8163503 | Moil Point | | | | | | | 1,599.00 |
| 8163504 | Conical Point | | | | | | | 1,599.00 |
| | * NPK E-225 | | | | | | | |
| 8162300 | Blunt End | 492 | 57" | 6.4650 | | 1 | 4.7930 | 2,737.00 |
| 8162301 | Flat Chisel Cross Cut | | | | | | | 2,737.00 |
| 8162302 | Flat Chisel In Line | | | | | | | 2,737.00 |
| 8162303 | Moil Point | | | | | | | 2,737.00 |
| 8162304 | Conical Point | | | | | | | 2,737.00 |
| | * NPK E-235 | | | | | | | |
| 8163400 | Blunt End | | 65 3/8" | 7.4680 | | 2 | 5.1180 | 5,681.00 |
| 8163401 | Flat Chisel Cross Cut | | | | | | | 5,681.00 |
| 8163402 | Flat Chisel In Line | | | | | | | 5,681.00 |
| 8163403 | Moil Point | | | | | | | 5,681.00 |
| 8163404 | Conical Point | | | | | | | 5,681.00 |
| | AJAX TAMPING PADS-stems sold seperately | | | | | | | |
| 8000001 | 8"x8" Square Tamping Pad | | | | | | | \$750.00 |
| 8000002 | 12"x12" Square Tamping Pad | | | | | | | \$1,100.00 |

**Note other point styles and lengths available upon request.



DEMOLITION TOOL PRICING



| PART No. | Point Description | WT lbs | O.A.L. | DIA. inch | Collar inch | No. of Slots | Shank Dia. In. | LIST PRICE |
|--|----------------------------|--------|---------|-----------|-------------|--------------|----------------|------------|
| * NPK E-265 | | | | | | | | |
| 8162900 | Blunt End | | 61" | 6.8660 | | 2 | 4.9500 | 3,476.00 |
| 8162901 | Flat Chisel Cross Cut | | | | | | | 3,476.00 |
| 8162902 | Flat Chisel In Line | | | | | | | 3,476.00 |
| 8162903 | Moil Point | | | | | | | 3,476.00 |
| 8162904 | Conical Point | | | | | | | 3,476.00 |
| * NPK E-210-A | | | | | | | | |
| 8161600 | Blunt End | 223 | 46-1/2" | 4.9480 | | 1 | 3.5430 | 1,315.00 |
| 8161601 | Flat Chisel Cross Cut | | | | | | | 1,315.00 |
| 8161602 | Flat Chisel In Line | | | | | | | 1,315.00 |
| 8161603 | Moil Point | | | | | | | 1,315.00 |
| 8161604 | Conical Point | | | | | | | 1,315.00 |
| * NPK E-224A | | | | | | | | |
| 8163000 | Blunt End | | 53 | 6.8110 | | 2 | 4.9520 | 3,019.00 |
| 8163001 | Flat Chisel Cross Cut | | | | | | | 3,019.00 |
| 8163002 | Flat Chisel In Line | | | | | | | 3,019.00 |
| 8163003 | Moil Point | | | | | | | 3,019.00 |
| 8163004 | Conical Point | | | | | | | 3,019.00 |
| * NPK E-240A | | | | | | | | |
| 8162400 | Blunt End | 708 | 64 1/2" | 7.2440 | | 1 | 5.3000 | 3,993.00 |
| 8162401 | Flat Chisel Cross Cut | | | | | | | 3,993.00 |
| 8162402 | Flat Chisel In Line | | | | | | | 3,993.00 |
| 8162403 | Moil Point | | | | | | | 3,993.00 |
| 8162404 | Conical Point | | | | | | | 3,993.00 |
| * NPK E-12-X/E-212 | | | | | | | | |
| 8161500 | Blunt End | 201 | 40" | 4.9610 | | 2 | 3.7800 | 1,155.00 |
| 8161501 | Flat Chisel Cross Cut | | | | | | | 1,155.00 |
| 8161502 | Flat Chisel In Line | | | | | | | 1,155.00 |
| 8161503 | Moil Point | | | | | | | 1,155.00 |
| 8161504 | Conical Point | | | | | | | 1,155.00 |
| NPK E-15-X/E-215 | | | | | | | | |
| 8162000 | Blunt End | 254 | 43 1/2" | 5.3540 | | 2 | 3.8980 | 1,519.00 |
| 8162001 | Flat Chisel Cross Cut | | | | | | | 1,519.00 |
| 8162002 | Flat Chisel In Line | | | | | | | 1,519.00 |
| 8162003 | Moil Point | | | | | | | 1,519.00 |
| 8162004 | Conical Point | | | | | | | 1,519.00 |
| * NPK E-24-X/E-224/E-220 | | | | | | | | |
| 8162200 | Blunt End | 403 | 53" | 6.1040 | | 2 | 4.3250 | 2,541.00 |
| 8162201 | Flat Chisel Cross Cut | | | | | | | 2,541.00 |
| 8162202 | Flat Chisel In Line | | | | | | | 2,541.00 |
| 8162203 | Moil Point | | | | | | | 2,541.00 |
| 8162204 | Conical Point | | | | | | | 2,541.00 |
| NPK H-06-X | | | | | | | | |
| 8160100 | Blunt End | 11 | 19" | 1.5750 | | 1 | 1.1020 | 126.00 |
| 8160101 | Flat Chisel Cross Cut | | | | | | | 126.00 |
| 8160102 | Flat Chisel In Line | | | | | | | 126.00 |
| 8160103 | Moil Point | | | | | | | 126.00 |
| 8160104 | Conical Point | | | | | | | 126.00 |
| NPK H-08-X | | | | | | | | |
| 8160200 | Blunt End | 11 | 19" | 1.7720 | | 1 | 1.3780 | 120.00 |
| 8160201 | Flat Chisel Cross Cut | | | | | | | 120.00 |
| 8160202 | Flat Chisel In Line | | | | | | | 120.00 |
| 8160203 | Moil Point | | | | | | | 120.00 |
| 8160204 | Conical Point | | | | | | | 120.00 |
| * NPK H-4-X/XE | | | | | | | | |
| 8160600 | Blunt End | 73 | 31 1/2" | 3.5220 | | 1 | 2.9440 | 507.00 |
| 8160601 | Flat Chisel Cross Cut | | | | | | | 507.00 |
| 8160602 | Flat Chisel In Line | | | | | | | 507.00 |
| 8160603 | Moil Point | | | | | | | 507.00 |
| 8160604 | Conical Point | | | | | | | 507.00 |
| AJAX TAMPING PADS-stems sold seperately | | | | | | | | |
| 8000001 | 8"x8" Square Tamping Pad | | | | | | | \$750.00 |
| 8000002 | 12"x12" Square Tamping Pad | | | | | | | \$1,100.00 |

**Note other point styles and lengths available upon request.



DEMOLITION TOOL PRICING

| PART No. | Point Description | WT lbs | O.A.L. | DIA. inch | Collar inch | No. of Slots | Shank Dia. In. | LIST PRICE |
|----------|---|--------|---------|-----------|-------------|--------------|----------------|------------|
| | NPK H-6-X | | | | | | | |
| 8160700 | Blunt End | 110 | 36 1/2" | 3.7400 | | 1 | | 674.00 |
| 8160701 | Flat Chisel Cross Cut | | | | | | | 674.00 |
| 8160702 | Flat Chisel In Line | | | | | | | 674.00 |
| 8160703 | Moil Point | | | | | | | 674.00 |
| 8160704 | Conical Point | | | | | | | 674.00 |
| | * NPK H-7-X | | | | | | | |
| 8160900 | Blunt End | 126 | 36 1/2" | 4.1340 | | 1 | 3.5430 | 724.00 |
| 8160901 | Flat Chisel Cross Cut | | | | | | | 724.00 |
| 8160902 | Flat Chisel In Line | | | | | | | 724.00 |
| 8160903 | Moil Point | | | | | | | 724.00 |
| 8160904 | Conical Point | | | | | | | 724.00 |
| | NPK H-8-X | | | | | | | |
| 8161000 | Blunt End | 110 | 36 1/2" | 4.1340 | | 1 | | 700.00 |
| 8161001 | Flat Chisel Cross Cut | | | | | | | 700.00 |
| 8161002 | Flat Chisel In Line | | | | | | | 700.00 |
| 8161003 | Moil Point | | | | | | | 700.00 |
| 8161004 | Conical Point | | | | | | | 700.00 |
| | NPK H-10-X | | | | | | | |
| 8161300 | Blunt End | 190 | 38 1/2" | 4.9610 | | 1 | | 1,016.00 |
| 8161301 | Flat Chisel Cross Cut | | | | | | | 1,016.00 |
| 8161302 | Flat Chisel In Line | | | | | | | 1,016.00 |
| 8161303 | Moil Point | | | | | | | 1,016.00 |
| 8161304 | Conical Point | | | | | | | 1,016.00 |
| | * NPK H-12-X/X-12-XE | | | | | | | |
| 8161700 | Blunt End | 280 | 47" | 5.3280 | | 1 | 4.1340 | 1,493.00 |
| 8161701 | Flat Chisel Cross Cut | | | | | | | 1,493.00 |
| 8161702 | Flat Chisel In Line | | | | | | | 1,493.00 |
| 8161703 | Moil Point | | | | | | | 1,493.00 |
| 8161704 | Conical Point | | | | | | | 1,493.00 |
| | * NPK H-20-X/H-20-XE | | | | | | | |
| 8162500 | Blunt End | | 54 1/2" | 6.1020 | | 1 | 4.7150 | 2,585.00 |
| 8162501 | Flat Chisel Cross Cut | | | | | | | 2,585.00 |
| 8162502 | Flat Chisel In Line | | | | | | | 2,585.00 |
| 8162503 | Moil Point | | | | | | | 2,585.00 |
| 8162504 | Conical Point | | | | | | | 2,585.00 |
| | NPK H-1-XA | | | | | | | |
| 8160300 | Blunt End | 22 | 23" | 2.2440 | | 1 | 1.7720 | 189.00 |
| 8160301 | Flat Chisel Cross Cut | | | | | | | 189.00 |
| 8160302 | Flat Chisel In Line | | | | | | | 189.00 |
| 8160303 | Moil Point | | | | | | | 189.00 |
| 8160304 | Conical Point | | | | | | | 189.00 |
| | NPK H-2-XA/XE | | | | | | | |
| 8160400 | Blunt End | 29 | 23 1/2" | 2.5590 | | 1 | 1.9690 | 241.00 |
| 8160401 | Flat Chisel Cross Cut | | | | | | | 241.00 |
| 8160402 | Flat Chisel In Line | | | | | | | 241.00 |
| 8160403 | Moil Point | | | | | | | 241.00 |
| 8160404 | Conical Point | | | | | | | 241.00 |
| | * NPK H-3-XA/XE/H-2-X | | | | | | | |
| 8160500 | Blunt End | 46 | 28 1/2" | 2.9530 | | 1 | 2.3620 | 370.00 |
| 8160501 | Flat Chisel Cross Cut | | | | | | | 370.00 |
| 8160502 | Flat Chisel In Line | | | | | | | 370.00 |
| 8160503 | Moil Point | | | | | | | 370.00 |
| 8160504 | Conical Point | | | | | | | 370.00 |
| | * NPK H-6-XA | | | | | | | |
| 8160800 | Blunt End | 102 | 36 | 3.7460 | | 1 | 2.9920 | 638.00 |
| 8160801 | Flat Chisel Cross Cut | | | | | | | 638.00 |
| 8160802 | Flat Chisel In Line | | | | | | | 638.00 |
| 8160803 | Moil Point | | | | | | | 638.00 |
| 8160804 | Conical Point | | | | | | | 638.00 |
| | AJAX TAMPING PADS -stems sold seperately | | | | | | | |
| 8000001 | 8"x8" Square Tamping Pad | | | | | | | \$750.00 |
| 8000002 | 12"x12" Square Tamping Pad | | | | | | | \$1,100.00 |

**Note other point styles and lengths available upon request.



DEMOLITION TOOL PRICING



| PART No. | Point Description | WT lbs | O.A.L. | DIA. inch | Collar inch | No. of Slots | Shank Dia. In. | LIST PRICE |
|--|----------------------------|--------|---------|-----------|-------------|--------------|----------------|------------|
| * NPK H-8-XA | | | | | | | | |
| 8161100 | Blunt End | 159 | 39 1/2" | 4.5330 | | 2 | 3.4650 | 964.00 |
| 8161101 | Flat Chisel Cross Cut | | | | | | | 964.00 |
| 8161102 | Flat Chisel In Line | | | | | | | 964.00 |
| 8161103 | Moil Point | | | | | | | 964.00 |
| 8161104 | Conical Point | | | | | | | 964.00 |
| * NPK H-10-XB/H-10-XE | | | | | | | | |
| 8161400 | Blunt End | 223 | 43 1/2" | 4.9610 | | 1 | 3.9370 | 1,281.00 |
| 8161401 | Flat Chisel Cross Cut | | | | | | | 1,281.00 |
| 8161402 | Flat Chisel In Line | | | | | | | 1,281.00 |
| 8161403 | Moil Point | | | | | | | 1,281.00 |
| 8161404 | Conical Point | | | | | | | 1,281.00 |
| * NPK H-16-X/H-16-XE | | | | | | | | |
| 8162100 | Blunt End | 348 | 51" | 5.7480 | | 1 | 4.3310 | 1,869.00 |
| 8162101 | Flat Chisel Cross Cut | | | | | | | 1,869.00 |
| 8162102 | Flat Chisel In Line | | | | | | | 1,869.00 |
| 8162103 | Moil Point | | | | | | | 1,869.00 |
| 8162104 | Conical Point | | | | | | | 1,869.00 |
| * OKADA TOP 45B | | | | | | | | |
| 8152600 | Blunt End | | 28" | 2.6770 | | 1 | 1.9640 | 320.00 |
| 8152601 | Flat Chisel Cross Cut | | | | | | | 320.00 |
| 8152602 | Flat Chisel In Line | | | | | | | 320.00 |
| 8152603 | Moil Point | | | | | | | 320.00 |
| 8152604 | Conical Point | | | | | | | 320.00 |
| * OKADA TOP 90 | | | | | | | | |
| 8152700 | Blunt End | | 37" | 3.8290 | | 2 | 2.9670 | 881.00 |
| 8152701 | Flat Chisel Cross Cut | | | | | | | 881.00 |
| 8152702 | Flat Chisel In Line | | | | | | | 881.00 |
| 8152703 | Moil Point | | | | | | | 881.00 |
| 8152704 | Conical Point | | | | | | | 881.00 |
| * OKADA TOP 200 | | | | | | | | |
| 8153000 | Blunt End | 210 | 43 1/4" | 4.8920 | n/a | 2 | 4.0260 | 1,310.00 |
| 8153001 | Flat Chisel Cross Cut | | | | | | | 1,310.00 |
| 8153002 | Flat Chisel In Line | | | | | | | 1,310.00 |
| 8153003 | Moil Point | | | | | | | 1,310.00 |
| 8153004 | Conical Point | | | | | | | 1,310.00 |
| * OKADA TOP 300 | | | | | | | | |
| 8152800 | Blunt End | | 55" | 6.0920 | | 2 | 4.9900 | 2,629.00 |
| 8152801 | Flat Chisel Cross Cut | | | | | | | 2,629.00 |
| 8152802 | Flat Chisel In Line | | | | | | | 2,629.00 |
| 8152803 | Moil Point | | | | | | | 2,629.00 |
| 8152804 | Conical Point | | | | | | | 2,629.00 |
| * OKADA UB-300 | | | | | | | | |
| 8152100 | Blunt End | | 18 3/4" | 1.9980 | | 1 | 1.5750 | 178.00 |
| 8152101 | Flat Chisel Cross Cut | | | | | | | 178.00 |
| 8152102 | Flat Chisel In Line | | | | | | | 178.00 |
| 8152103 | Moil Point | | | | | | | 178.00 |
| 8152104 | Conical Point | | | | | | | 178.00 |
| * OKADA UB-301 | | | | | | | | |
| 8150800 | Blunt End | | 19 3/4" | 1.9980 | | 1 | 1.5750 | 183.00 |
| 8150801 | Flat Chisel Cross Cut | | | | | | | 183.00 |
| 8150802 | Flat Chisel In Line | | | | | | | 183.00 |
| 8150803 | Moil Point | | | | | | | 183.00 |
| 8150804 | Conical Point | | | | | | | 183.00 |
| * OKADA UB-302 | | | | | | | | |
| 8150900 | Blunt End | | 21 3/4" | 2.4050 | | 1 | 1.7720 | 196.00 |
| 8150901 | Flat Chisel Cross Cut | | | | | | | 196.00 |
| 8150902 | Flat Chisel In Line | | | | | | | 196.00 |
| 8150903 | Moil Point | | | | | | | 196.00 |
| 8150904 | Conical Point | | | | | | | 196.00 |
| AJAX TAMPING PADS - stems sold seperately | | | | | | | | |
| 8000001 | 8"x8" Square Tamping Pad | | | | | | | \$750.00 |
| 8000002 | 12"x12" Square Tamping Pad | | | | | | | \$1,100.00 |

**Note other point styles and lengths available upon request.



DEMOLITION TOOL PRICING

| PART No. | Point Description | WT lbs | O.A.L. | DIA. inch | Collar inch | No. of Slots | Shank Dia. In. | LIST PRICE |
|--|----------------------------|--------|---------|-----------|-------------|--------------|----------------|------------|
| * OKADA UB-302A/TOP 35 | | | | | | | | |
| 8151000 | Blunt End | | 23 5/8" | 2.3650 | | 1 | 1.7720 | 199.00 |
| 8151001 | Flat Chisel Cross Cut | | | | | | | 199.00 |
| 8151002 | Flat Chisel In Line | | | | | | | 199.00 |
| 8151003 | Moil Point | | | | | | | 199.00 |
| 8151004 | Conical Point | | | | | | | 199.00 |
| * OKADA OKB-303 | | | | | | | | |
| 8151100 | Blunt End | 39 | 27 1/2" | 2.6770 | | 1 | 1.9690 | 316.00 |
| 8151101 | Flat Chisel Cross Cut | | | | | | | 316.00 |
| 8151102 | Flat Chisel In Line | | | | | | | 316.00 |
| 8151103 | Moil Point | | | | | | | 316.00 |
| 8151104 | Conical Point | | | | | | | 316.00 |
| * OKADA UB-304 | | | | | | | | |
| 8151200 | Blunt End | | 27 1/2" | 2.9100 | | 1 | 2.3690 | 350.00 |
| 8151201 | Flat Chisel Cross Cut | | | | | | | 350.00 |
| 8151202 | Flat Chisel In Line | | | | | | | 350.00 |
| 8151203 | Moil Point | | | | | | | 350.00 |
| 8151204 | Conical Point | | | | | | | 350.00 |
| * OKADA UB-304B | | | | | | | | |
| 8151300 | Blunt End | | 29 1/2" | 2.9000 | | 1 | 2.1920 | 374.00 |
| 8151301 | Flat Chisel Cross Cut | | | | | | | 374.00 |
| 8151302 | Flat Chisel In Line | | | | | | | 374.00 |
| 8151303 | Moil Point | | | | | | | 374.00 |
| 8151304 | Conical Point | | | | | | | 374.00 |
| * OKADA OKB-305 | | | | | | | | |
| 8151400 | Blunt End | 80 | 35 1/2" | 3.3460 | | 1 | 2.3620 | 566.00 |
| 8151401 | Flat Chisel Cross Cut | | | | | | | 566.00 |
| 8151402 | Flat Chisel In Line | | | | | | | 566.00 |
| 8151403 | Moil Point | | | | | | | 566.00 |
| 8151404 | Conical Point | | | | | | | 566.00 |
| * OKADA UB-307 | | | | | | | | |
| 8152200 | Blunt End | | 38" | 3.9320 | | 1 | 2.9590 | 898.00 |
| 8152201 | Flat Chisel Cross Cut | | | | | | | 898.00 |
| 8152202 | Flat Chisel In Line | | | | | | | 898.00 |
| 8152203 | Moil Point | | | | | | | 898.00 |
| 8152204 | Conical Point | | | | | | | 898.00 |
| * OKADA UB-308 | | | | | | | | |
| 8151600 | Blunt End | | 39 1/2" | 4.3230 | | 2 | 3.3450 | 979.00 |
| 8151601 | Flat Chisel Cross Cut | | | | | | | 979.00 |
| 8151602 | Flat Chisel In Line | | | | | | | 979.00 |
| 8151603 | Moil Point | | | | | | | 979.00 |
| 8151604 | Conical Point | | | | | | | 979.00 |
| * OKADA UB-310 | | | | | | | | |
| 8151700 | Blunt End | | 43 1/2" | 4.7500 | | 2 | 3.5000 | 1,281.00 |
| 8151701 | Flat Chisel Cross Cut | | | | | | | 1,281.00 |
| 8151702 | Flat Chisel In Line | | | | | | | 1,281.00 |
| 8151703 | Moil Point | | | | | | | 1,281.00 |
| 8151704 | Conical Point | | | | | | | 1,281.00 |
| * OKADA UB-312 | | | | | | | | |
| 8151800 | Blunt End | | 45 1/2" | 5.1130 | | 2 | 4.2470 | 1,367.00 |
| 8151801 | Flat Chisel Cross Cut | | | | | | | 1,367.00 |
| 8151802 | Flat Chisel In Line | | | | | | | 1,367.00 |
| 8151803 | Moil Point | | | | | | | 1,367.00 |
| 8151804 | Conical Point | | | | | | | 1,367.00 |
| * OKADA UB-316 | | | | | | | | |
| 8151900 | Blunt End | | 51" | 5.5060 | | 2 | 4.5530 | 1,831.00 |
| 8151901 | Flat Chisel Cross Cut | | | | | | | 1,831.00 |
| 8151902 | Flat Chisel In Line | | | | | | | 1,831.00 |
| 8151903 | Moil Point | | | | | | | 1,831.00 |
| 8151904 | Conical Point | | | | | | | 1,831.00 |
| AJAX TAMPING PADS-stems sold seperately | | | | | | | | |
| 8000001 | 8"x8" Square Tamping Pad | | | | | | | \$750.00 |
| 8000002 | 12"x12" Square Tamping Pad | | | | | | | \$1,100.00 |

**Note other point styles and lengths available upon request.



DEMOLITION TOOL PRICING



| PART No. | Point Description | WT lbs | O.A.L. | DIA. inch | Collar inch | No. of Slots | Shank Dia. In. | LIST PRICE |
|--|----------------------------|--------|---------|-----------|-------------|--------------|----------------|------------|
| * OKADA UB-318 | | | | | | | | |
| 8152000 | Blunt End | | 55" | 5.8890 | | 2 | 4.7150 | 1,961.00 |
| 8152001 | Flat Chisel Cross Cut | | | | | | | 1,961.00 |
| 8152002 | Flat Chisel In Line | | | | | | | 1,961.00 |
| 8152003 | Moil Point | | | | | | | 1,961.00 |
| 8152004 | Conical Point | | | | | | | 1,961.00 |
| * OKADA UB-324 | | | | | | | | |
| 8152300 | Blunt End | | 63" | 6.6520 | | 2 | 5.3500 | 2,633.00 |
| 8152301 | Flat Chisel Cross Cut | | | | | | | 2,633.00 |
| 8152302 | Flat Chisel In Line | | | | | | | 2,633.00 |
| 8152303 | Moil Point | | | | | | | 2,633.00 |
| 8152304 | Conical Point | | | | | | | 2,633.00 |
| * OKADA UB-324A | | | | | | | | |
| 8152400 | Blunt End | | 63" | 6.6340 | | 2 | 5.3440 | 2,633.00 |
| 8152401 | Flat Chisel Cross Cut | | | | | | | 2,633.00 |
| 8152402 | Flat Chisel In Line | | | | | | | 2,633.00 |
| 8152403 | Moil Point | | | | | | | 2,633.00 |
| 8152404 | Conical Point | | | | | | | 2,633.00 |
| * OKADA UB-330 | | | | | | | | |
| 8152500 | Blunt End | | 71" | 7.3000 | | 1 | 5.7000 | 4,890.00 |
| 8152501 | Flat Chisel Cross Cut | | | | | | | 4,890.00 |
| 8152502 | Flat Chisel In Line | | | | | | | 4,890.00 |
| 8152503 | Moil Point | | | | | | | 4,890.00 |
| 8152504 | Conical Point | | | | | | | 4,890.00 |
| RAMMER Piccolo | | | | | | | | |
| 8170100 | Blunt End | 8 | 16" | 1.5750 | | 2 | | 124.00 |
| 8170101 | Flat Chisel Cross Cut | | | | | | | 124.00 |
| 8170102 | Flat Chisel In Line | | | | | | | 124.00 |
| 8170103 | Moil Point | | | | | | | 124.00 |
| 8170104 | Conical Point | | | | | | | 124.00 |
| * RAMMER E 64 | | | | | | | | |
| 8171000 | Blunt End | 143 | 41 1/2" | 4.1730 | | 2 | | 816.00 |
| 8171001 | Flat Chisel Cross Cut | | | | | | | 816.00 |
| 8171002 | Flat Chisel In Line | | | | | | | 816.00 |
| 8171003 | Moil Point | | | | | | | 816.00 |
| 8171004 | Conical Point | | | | | | | 816.00 |
| * RAMMER E 66/E 66N (S 55) | | | | | | | | |
| 8171200 | Blunt End | 172 | 41 1/2" | 4.5280 | | 2 | | 959.00 |
| 8171201 | Flat Chisel Cross Cut | | | | | | | 959.00 |
| 8171202 | Flat Chisel In Line | | | | | | | 959.00 |
| 8171203 | Moil Point | | | | | | | 959.00 |
| 8171204 | Conical Point | | | | | | | 959.00 |
| * RAMMER E 68 SAME AS CATERPILLAR H130 | | | | | | | | |
| 8171400 | Blunt End | 223 | 43 1/2" | 5.1180 | | 2 | | 1,231.00 |
| 8171401 | Flat Chisel Cross Cut | | | | | | | 1,231.00 |
| 8171402 | Flat Chisel In Line | | | | | | | 1,231.00 |
| 8171403 | Moil Point | | | | | | | 1,231.00 |
| 8171404 | Conical Point | | | | | | | 1,231.00 |
| * RAMMER G 80 | | | | | | | | |
| 8171800 | Blunt End | 287 | 47" | 5.5120 | | 2 | | 1,607.00 |
| 8171801 | Flat Chisel Cross Cut | | | | | | | 1,607.00 |
| 8171802 | Flat Chisel In Line | | | | | | | 1,607.00 |
| 8171803 | Moil Point | | | | | | | 1,607.00 |
| 8171804 | Conical Point | | | | | | | 1,607.00 |
| RAMMER G 100 | | | | | | | | |
| 8172100 | Blunt End | 511 | 57" | 6.6930 | | 2 | | 3,068.00 |
| 8172101 | Flat Chisel Cross Cut | | | | | | | 3,068.00 |
| 8172102 | Flat Chisel In Line | | | | | | | 3,068.00 |
| 8172103 | Moil Point | | | | | | | 3,068.00 |
| 8172104 | Conical Point | | | | | | | 3,068.00 |
| AJAX TAMPING PADS-stems sold seperately | | | | | | | | |
| 8000001 | 8"x8" Square Tamping Pad | | | | | | | \$750.00 |
| 8000002 | 12"x12" Square Tamping Pad | | | | | | | \$1,100.00 |

**Note other point styles and lengths available upon request.



DEMOLITION TOOL PRICING

| PART No. | Point Description | WT lbs | O.A.L. | DIA. inch | Collar inch | No. of Slots | Shank Dia. In. | LIST PRICE |
|----------|--|--------------------------|---------|-----------|-------------|--------------|----------------|------------|
| | RAMMER S20 | | | | | | | |
| 8170400 | Blunt End | 17 | 21" | 2.0870 | | 1 | 1.4960 | 170.00 |
| 8170401 | Flat Chisel Cross Cut | | | | | | | 170.00 |
| 8170402 | Flat Chisel In Line | | | | | | | 170.00 |
| 8170403 | Moil Point | | | | | | | 170.00 |
| 8170404 | Conical Point | | | | | | | 170.00 |
| | * RAMMER S 21 | | | | | | | |
| 8170200 | Blunt End | 11 | 19" | 1.7720 | | 1 | | 112.00 |
| 8170201 | Flat Chisel Cross Cut | | | | | | | 112.00 |
| 8170202 | Flat Chisel In Line | | | | | | | 112.00 |
| 8170203 | Moil Point | | | | | | | 112.00 |
| 8170204 | Conical Point | | | | | | | 112.00 |
| | * RAMMER S 22 | | | | | | | |
| 8170300 | Blunt End | 15 | 20" | 1.9690 | | 2 | | 147.00 |
| 8170301 | Flat Chisel Cross Cut | | | | | | | 147.00 |
| 8170302 | Flat Chisel In Line | | | | | | | 147.00 |
| 8170303 | Moil Point | | | | | | | 147.00 |
| 8170304 | Conical Point | | | | | | | 147.00 |
| | * RAMMER S 23/S 23N | | | | | | | |
| 8170500 | Blunt End | 33 | 27 1/2" | 2.4800 | | 1 | | 271.00 |
| 8170501 | Flat Chisel Cross Cut | | | | | | | 271.00 |
| 8170502 | Flat Chisel In Line | | | | | | | 271.00 |
| 8170503 | Moil Point | | | | | | | 271.00 |
| 8170504 | Conical Point | | | | | | | 271.00 |
| | RAMMER S 24 | | | | | | | |
| 8170700 | Blunt End | 46 | 28 1/2" | 2.8350 | | 1 | | 385.00 |
| 8170701 | Flat Chisel Cross Cut | | | | | | | 385.00 |
| 8170702 | Flat Chisel In Line | | | | | | | 385.00 |
| 8170703 | Moil Point | | | | | | | 385.00 |
| 8170704 | Conical Point | | | | | | | 385.00 |
| | * RAMMER S 25 | SAME AS JCB HM360 | | | | | | |
| 8170600 | Blunt End | 42 | 29" | 2.7560 | | 2 | | 318.00 |
| 8170601 | Flat Chisel Cross Cut | | | | | | | 318.00 |
| 8170602 | Flat Chisel In Line | | | | | | | 318.00 |
| 8170603 | Moil Point | | | | | | | 318.00 |
| 8170604 | Conical Point | | | | | | | 318.00 |
| | RAMMER S 26/S 26N | | | | | | | |
| 8170800 | Blunt End | 79 | 35" | 3.5430 | | 1 | 2.9130 | 567.00 |
| 8170801 | Flat Chisel Cross Cut | | | | | | | 567.00 |
| 8170802 | Flat Chisel In Line | | | | | | | 567.00 |
| 8170803 | Moil Point | | | | | | | 567.00 |
| 8170804 | Conical Point | | | | | | | 567.00 |
| | * RAMMER S27/27C | | | | | | | |
| 8172200 | Blunt End | | 35" | 3.3070 | | 2 | | 553.00 |
| 8172201 | Flat Chisel Cross Cut | | | | | | | 553.00 |
| 8172202 | Flat Chisel In Line | | | | | | | 553.00 |
| 8172203 | Moil Point | | | | | | | 553.00 |
| 8172204 | Conical Point | | | | | | | 553.00 |
| | * RAMMER S 29 | | | | | | | |
| 8170900 | Blunt End | 88 | 33" | 3.7400 | | 2 | | 588.00 |
| 8170901 | Flat Chisel Cross Cut | | | | | | | 588.00 |
| 8170902 | Flat Chisel In Line | | | | | | | 588.00 |
| 8170903 | Moil Point | | | | | | | 588.00 |
| 8170904 | Conical Point | | | | | | | 588.00 |
| | RAMMER S 52 | | | | | | | |
| 8171100 | Blunt End | 123 | 35 1/2" | 4.3310 | | 1 | 3.8980 | 813.00 |
| 8171101 | Flat Chisel Cross Cut | | | | | | | 813.00 |
| 8171102 | Flat Chisel In Line | | | | | | | 813.00 |
| 8171103 | Moil Point | | | | | | | 813.00 |
| 8171104 | Conical Point | | | | | | | 813.00 |
| | AJAX TAMPING PADS - stems sold seperately | | | | | | | |
| 8000001 | 8"x8" Square Tamping Pad | | | | | | | \$750.00 |
| 8000002 | 12"x12" Square Tamping Pad | | | | | | | \$1,100.00 |

**Note other point styles and lengths available upon request.



DEMOLITION TOOL PRICING



| PART No. | Point Description | WT lbs | O.A.L. | DIA. inch | Collar inch | No. of Slots | Shank Dia. In. | LIST PRICE |
|---|----------------------------|--------|---------|-----------|-------------|--------------|----------------|------------|
| RAMMER S 54 (700/700S) | | | | | | | | |
| 8171300 | Blunt End | 172 | 41 1/2" | 4.5280 | | 1 | | 991.00 |
| 8171301 | Flat Chisel Cross Cut | | | | | | | 991.00 |
| 8171302 | Flat Chisel In Line | | | | | | | 991.00 |
| 8171303 | Moil Point | | | | | | | 991.00 |
| 8171304 | Conical Point | | | | | | | 991.00 |
| RAMMER S 56 (800/800S) | | | | | | | | |
| 8171500 | Blunt End | 225 | 43 1/2" | 5.1180 | | 1 | | 1,182.00 |
| 8171501 | Flat Chisel Cross Cut | | | | | | | 1,182.00 |
| 8171502 | Flat Chisel In Line | | | | | | | 1,182.00 |
| 8171503 | Moil Point | | | | | | | 1,182.00 |
| 8171504 | Conical Point | | | | | | | 1,182.00 |
| RAMMER S 82 (S 1400) | | | | | | | | |
| 8171600 | Blunt End | 287 | 47" | 5.5120 | | 2 | | 1,541.00 |
| 8171601 | Flat Chisel Cross Cut | | | | | | | 1,541.00 |
| 8171602 | Flat Chisel In Line | | | | | | | 1,541.00 |
| 8171603 | Moil Point | | | | | | | 1,541.00 |
| 8171604 | Conical Point | | | | | | | 1,541.00 |
| * RAMMER S 83 SAME AS CATERPILLAR H140 | | | | | | | | |
| 8171700 | Blunt End | 287 | 47" | 5.5120 | | 2 | | 1,541.00 |
| 8171701 | Flat Chisel Cross Cut | | | | | | | 1,541.00 |
| 8171702 | Flat Chisel In Line | | | | | | | 1,541.00 |
| 8171703 | Moil Point | | | | | | | 1,541.00 |
| 8171704 | Conical Point | | | | | | | 1,541.00 |
| RAMMER S 84 (S 1600) | | | | | | | | |
| 8171900 | Blunt End | 403 | 51" | 6.2990 | | 2 | | 2,185.00 |
| 8171901 | Flat Chisel Cross Cut | | | | | | | 2,185.00 |
| 8171902 | Flat Chisel In Line | | | | | | | 2,185.00 |
| 8171903 | Moil Point | | | | | | | 2,185.00 |
| 8171904 | Conical Point | | | | | | | 2,185.00 |
| * RAMMER S 86 (S 2000) | | | | | | | | |
| 8172000 | Blunt End | 516 | 57" | 6.6930 | | 1 | | 3,385.00 |
| 8172001 | Flat Chisel Cross Cut | | | | | | | 3,385.00 |
| 8172002 | Flat Chisel In Line | | | | | | | 3,385.00 |
| 8172003 | Moil Point | | | | | | | 3,385.00 |
| 8172004 | Conical Point | | | | | | | 3,385.00 |
| * ROCKBLASTER RB50 SSG | | | | | | | | |
| 8220100 | Blunt End | | 23" | 2.2720 | | 1 | 1.6340 | 201.00 |
| 8220101 | Flat Chisel Cross Cut | | | | | | | 201.00 |
| 8220102 | Flat Chisel In Line | | | | | | | 201.00 |
| 8220103 | Moil Point | | | | | | | 201.00 |
| 8220104 | Conical Point | | | | | | | 201.00 |
| * ROCKBLASTER RB125 | | | | | | | | |
| 8220200 | Blunt End | 46 | 27 1/2" | 3.1500 | | 2 | 2.5590 | 403.00 |
| 8220201 | Flat Chisel Cross Cut | | | | | | | 403.00 |
| 8220202 | Flat Chisel In Line | | | | | | | 403.00 |
| 8220203 | Moil Point | | | | | | | 403.00 |
| 8220204 | Conical Point | | | | | | | 403.00 |
| * ROCKBLASTER RB125G | | | | | | | | |
| 8220300 | Blunt End | | 33" | 3.1250 | | 1 | 2.3650 | 447.00 |
| 8220301 | Flat Chisel Cross Cut | | | | | | | 447.00 |
| 8220302 | Flat Chisel In Line | | | | | | | 447.00 |
| 8220303 | Moil Point | | | | | | | 447.00 |
| 8220304 | Conical Point | | | | | | | 447.00 |
| * ROCKBLASTER RB250 | | | | | | | | |
| 8220400 | Blunt End | 93 | 33" | 3.7010 | | 2 | | 629.00 |
| 8220401 | Flat Chisel Cross Cut | | | | | | | 629.00 |
| 8220402 | Flat Chisel In Line | | | | | | | 629.00 |
| 8220403 | Moil Point | | | | | | | 629.00 |
| 8220404 | Conical Point | | | | | | | 629.00 |
| AJAX TAMPING PADS -stems sold seperately | | | | | | | | |
| 8000001 | 8"x8" Square Tamping Pad | | | | | | | \$750.00 |
| 8000002 | 12"x12" Square Tamping Pad | | | | | | | \$1,100.00 |

**Note other point styles and lengths available upon request.



DEMOLITION TOOL PRICING

| PART No. | Point Description | WT lbs | O.A.L. | DIA. inch | Collar inch | No. of Slots | Shank Dia. In. | LIST PRICE |
|--|----------------------------|--------|---------|-----------|-------------|--------------|----------------|------------|
| * ROCKBLASTER RB250G | | | | | | | | |
| 8220500 | Blunt End | | 32" | 3.3170 | | 2 | 2.5810 | 529.00 |
| 8220501 | Flat Chisel Cross Cut | | | | | | | 529.00 |
| 8220502 | Flat Chisel In Line | | | | | | | 529.00 |
| 8220503 | Moil Point | | | | | | | 529.00 |
| 8220504 | Conical Point | | | | | | | 529.00 |
| * ROCKBLASTER RB500G | | | | | | | | |
| 8220600 | Blunt End | | 41 1/2" | 3.8950 | | 2 | 3.0300 | 959.00 |
| 8220601 | Flat Chisel Cross Cut | | | | | | | 959.00 |
| 8220602 | Flat Chisel In Line | | | | | | | 959.00 |
| 8220603 | Moil Point | | | | | | | 959.00 |
| 8220604 | Conical Point | | | | | | | 959.00 |
| * ROCKBLASTER RB501C | | | | | | | | |
| 8220700 | Blunt End | 159 | 39 1/2" | 4.4880 | | 2 | | 939.00 |
| 8220701 | Flat Chisel Cross Cut | | | | | | | 939.00 |
| 8220702 | Flat Chisel In Line | | | | | | | 939.00 |
| 8220703 | Moil Point | | | | | | | 939.00 |
| 8220704 | Conical Point | | | | | | | 939.00 |
| * ROCKBLASTER RB750 | | | | | | | | |
| 8220800 | Blunt End | 190 | 43 1/2" | 4.7240 | | 2 | 3.9370 | 1,221.00 |
| 8220801 | Flat Chisel Cross Cut | | | | | | | 1,221.00 |
| 8220802 | Flat Chisel In Line | | | | | | | 1,221.00 |
| 8220803 | Moil Point | | | | | | | 1,221.00 |
| 8220804 | Conical Point | | | | | | | 1,221.00 |
| * ROCKBLASTER RB750G | | | | | | | | |
| 8220900 | Blunt End | | 43 1/2" | 4.6920 | | 2 | | 992.00 |
| 8220901 | Flat Chisel Cross Cut | | | | | | | 992.00 |
| 8220902 | Flat Chisel In Line | | | | | | | 992.00 |
| 8220903 | Moil Point | | | | | | | 992.00 |
| 8220904 | Conical Point | | | | | | | 992.00 |
| * ROCKBLASTER RB1000G | | | | | | | | |
| 8221000 | Blunt End | | 47" | 5.2800 | | 2 | | 1,385.00 |
| 8221001 | Flat Chisel Cross Cut | | | | | | | 1,385.00 |
| 8221002 | Flat Chisel In Line | | | | | | | 1,385.00 |
| 8221003 | Moil Point | | | | | | | 1,385.00 |
| 8221004 | Conical Point | | | | | | | 1,385.00 |
| * ROCKBLASTER RB1100 | | | | | | | | |
| 8221100 | Blunt End | 298 | 53" | 5.5120 | | 2 | 4.5280 | 2,139.00 |
| 8221101 | Flat Chisel Cross Cut | | | | | | | 2,139.00 |
| 8221102 | Flat Chisel In Line | | | | | | | 2,139.00 |
| 8221103 | Moil Point | | | | | | | 2,139.00 |
| 8221104 | Conical Point | | | | | | | 2,139.00 |
| * ROCKBLASTER RB1200G | | | | | | | | |
| 8221500 | Blunt End | | 47" | 5.4800 | | 2 | | 1,541.00 |
| 8221501 | Flat Chisel Cross Cut | | | | | | | 1,541.00 |
| 8221502 | Flat Chisel In Line | | | | | | | 1,541.00 |
| 8221503 | Moil Point | | | | | | | 1,541.00 |
| 8221504 | Conical Point | | | | | | | 1,541.00 |
| * ROCKBLASTER RB1300G | | | | | | | | |
| 8221200 | Blunt End | | 51" | 5.8850 | | 2 | | 1,879.00 |
| 8221201 | Flat Chisel Cross Cut | | | | | | | 1,879.00 |
| 8221202 | Flat Chisel In Line | | | | | | | 1,879.00 |
| 8221203 | Moil Point | | | | | | | 1,879.00 |
| 8221204 | Conical Point | | | | | | | 1,879.00 |
| * ROCKBLASTER RB1500G | | | | | | | | |
| 8221300 | Blunt End | | 56" | 6.0720 | | 2 | | 2,674.00 |
| 8221301 | Flat Chisel Cross Cut | | | | | | | 2,674.00 |
| 8221302 | Flat Chisel In Line | | | | | | | 2,674.00 |
| 8221303 | Moil Point | | | | | | | 2,674.00 |
| 8221304 | Conical Point | | | | | | | 2,674.00 |
| AJAX TAMPING PADS - stems sold seperately | | | | | | | | |
| 8000001 | 8"x8" Square Tamping Pad | | | | | | | \$750.00 |
| 8000002 | 12"x12" Square Tamping Pad | | | | | | | \$1,100.00 |

**Note other point styles and lengths available upon request.



DEMOLITION TOOL PRICING



| PART No. | Point Description | WT lbs | O.A.L. | DIA. inch | Collar inch | No. of Slots | Shank Dia. In. | LIST PRICE |
|--|----------------------------|--------|---------|-----------|-------------|--------------|----------------|------------|
| * ROCKBLASTER RB1800G | | | | | | | | |
| 8221600 | Blunt End | | 51 1/2" | 6.2660 | | 2 | | 2,204.00 |
| 8221601 | Flat Chisel Cross Cut | | | | | | | 2,204.00 |
| 8221602 | Flat Chisel In Line | | | | | | | 2,204.00 |
| 8221603 | Moil Point | | | | | | | 2,204.00 |
| 8221604 | Conical Point | | | | | | | 2,204.00 |
| * ROCKBLASTER RB1900G | | | | | | | | |
| 8221700 | Blunt End | | 57 1/2" | 6.6570 | | 2 | | 2,946.00 |
| 8221701 | Flat Chisel Cross Cut | | | | | | | 2,946.00 |
| 8221702 | Flat Chisel In Line | | | | | | | 2,946.00 |
| 8221703 | Moil Point | | | | | | | 2,946.00 |
| 8221704 | Conical Point | | | | | | | 2,946.00 |
| * ROCKBLASTER RB2000 | | | | | | | | |
| 8221400 | Blunt End | | 57 | 6.6530 | | 2 | | 2,923.00 |
| 8221401 | Flat Chisel Cross Cut | | | | | | | 2,923.00 |
| 8221402 | Flat Chisel In Line | | | | | | | 2,923.00 |
| 8221403 | Moil Point | | | | | | | 2,923.00 |
| 8221404 | Conical Point | | | | | | | 2,923.00 |
| * SOCOMEC DMS 50 | | | | | | | | |
| 8230400 | Blunt End | 11 | 19" | 1.7720 | | 1 | | 112.00 |
| 8230401 | Flat Chisel Cross Cut | | | | | | | 112.00 |
| 8230402 | Flat Chisel In Line | | | | | | | 112.00 |
| 8230403 | Moil Point | | | | | | | 112.00 |
| 8230404 | Conical Point | | | | | | | 112.00 |
| * SOCOMEC DMS 95 | | | | | | | | |
| 8230300 | Blunt End | 11 | 20 1/2" | 1.7480 | | 1 | 1.4880 | 125.00 |
| 8230301 | Flat Chisel Cross Cut | | | | | | | 125.00 |
| 8230302 | Flat Chisel In Line | | | | | | | 125.00 |
| 8230303 | Moil Point | | | | | | | 125.00 |
| 8230304 | Conical Point | | | | | | | 125.00 |
| * SOCOMEC DMS 160 | | | | | | | | |
| 8230500 | Blunt End | 19 | 21" | 2.1650 | | 1 | | 158.00 |
| 8230501 | Flat Chisel Cross Cut | | | | | | | 158.00 |
| 8230502 | Flat Chisel In Line | | | | | | | 158.00 |
| 8230503 | Moil Point | | | | | | | 158.00 |
| 8230504 | Conical Point | | | | | | | 158.00 |
| * SOCOMEC DMS 220 | | | | | | | | |
| 8230600 | Blunt End | 29 | 23 1/2" | 2.5590 | | 1 | | 238.00 |
| 8230601 | Flat Chisel Cross Cut | | | | | | | 238.00 |
| 8230602 | Flat Chisel In Line | | | | | | | 238.00 |
| 8230603 | Moil Point | | | | | | | 238.00 |
| 8230604 | Conical Point | | | | | | | 238.00 |
| * SOCOMEC DMS 270 | | | | | | | | |
| 8230700 | Blunt End | 43 | 29" | 2.6770 | | 1 | | 309.00 |
| 8230701 | Flat Chisel Cross Cut | | | | | | | 309.00 |
| 8230702 | Flat Chisel In Line | | | | | | | 309.00 |
| 8230703 | Moil Point | | | | | | | 309.00 |
| 8230704 | Conical Point | | | | | | | 309.00 |
| * SOCOMEC DMS 330 | | | | | | | | |
| 8230100 | Blunt End | 51 | 27-5/8" | 2.8350 | | 1 | 2.323 | 345.00 |
| 8230101 | Flat Chisel Cross Cut | | | | | | | 345.00 |
| 8230102 | Flat Chisel In Line | | | | | | | 345.00 |
| 8230103 | Moil Point | | | | | | | 345.00 |
| 8230104 | Conical Point | | | | | | | 345.00 |
| * SOCOMEC MDO 550 | | | | | | | | |
| 8230800 | Blunt End | 106 | 38" | 3.7400 | | 1 | | 611.00 |
| 8230801 | Flat Chisel Cross Cut | | | | | | | 611.00 |
| 8230802 | Flat Chisel In Line | | | | | | | 611.00 |
| 8230803 | Moil Point | | | | | | | 611.00 |
| 8230804 | Conical Point | | | | | | | 611.00 |
| AJAX TAMPING PADS - stems sold seperately | | | | | | | | |
| 8000001 | 8"x8" Square Tamping Pad | | | | | | | \$750.00 |
| 8000002 | 12"x12" Square Tamping Pad | | | | | | | \$1,100.00 |

**Note other point styles and lengths available upon request.



DEMOLITION TOOL PRICING

| PART No. | Point Description | WT lbs | O.A.L. | DIA. inch | Collar inch | No. of Slots | Shank Dia. In. | LIST PRICE |
|--|----------------------------|--------|---------|-----------|-------------|--------------|----------------|------------|
| SOCOMEK MDO 750TS | | | | | | | | |
| 8230900 | Blunt End | 168 | 41 1/2" | 4.5280 | | 1 | | 959.00 |
| 8230901 | Flat Chisel Cross Cut | | | | | | | 959.00 |
| 8230902 | Flat Chisel In Line | | | | | | | 959.00 |
| 8230903 | Moil Point | | | | | | | 959.00 |
| 8230904 | Conical Point | | | | | | | 959.00 |
| * SOCOMEK MDO 1450TS | | | | | | | | |
| 8230200 | Blunt End | 231 | 45 1/4" | 5.1180 | | 1 | | 1,231.00 |
| 8230201 | Flat Chisel Cross Cut | | | | | | | 1,231.00 |
| 8230202 | Flat Chisel In Line | | | | | | | 1,231.00 |
| 8230203 | Moil Point | | | | | | | 1,231.00 |
| 8230204 | Conical Point | | | | | | | 1,231.00 |
| SOCOMEK MDO 1950TS | | | | | | | | |
| 8231000 | Blunt End | 273 | 47" | 5.5120 | | 1 | | 1,541.00 |
| 8231001 | Flat Chisel Cross Cut | | | | | | | 1,541.00 |
| 8231002 | Flat Chisel In Line | | | | | | | 1,541.00 |
| 8231003 | Moil Point | | | | | | | 1,541.00 |
| 8231004 | Conical Point | | | | | | | 1,541.00 |
| SOCOMEK MDO 2050TS | | | | | | | | |
| 8231100 | Blunt End | 375 | 52 1/2" | 6.1020 | | 2 | 4.724 | 2,253.00 |
| 8231101 | Flat Chisel Cross Cut | | | | | | | 2,253.00 |
| 8231102 | Flat Chisel In Line | | | | | | | 2,253.00 |
| 8231103 | Moil Point | | | | | | | 2,253.00 |
| 8231104 | Conical Point | | | | | | | 2,253.00 |
| * SOOSAN SB10 | | | | | | | | |
| 8250100 | Blunt End | 9 | 18 | 1.5580 | | 1 | 1.207 | 138.00 |
| 8250101 | Flat Chisel Cross Cut | | | | | | | 138.00 |
| 8250102 | Flat Chisel In Line | | | | | | | 138.00 |
| 8250103 | Moil Point | | | | | | | 138.00 |
| 8250104 | Conical Point | | | | | | | 138.00 |
| * SOOSAN SB20 | | | | | | | | |
| 8250200 | Blunt End | 12 | 20 | 1.7540 | | 1 | 1.363 | 155.00 |
| 8250201 | Flat Chisel Cross Cut | | | | | | | 155.00 |
| 8250202 | Flat Chisel In Line | | | | | | | 155.00 |
| 8250203 | Moil Point | | | | | | | 155.00 |
| 8250204 | Conical Point | | | | | | | 155.00 |
| SOCOMEK MDO 2050TS | | | | | | | | |
| 8250300 | Blunt End | 19 | 22 | 2.0730 | | 1 | 1.620 | 192.00 |
| 8250301 | Flat Chisel Cross Cut | | | | | | | 192.00 |
| 8250302 | Flat Chisel In Line | | | | | | | 192.00 |
| 8250303 | Moil Point | | | | | | | 192.00 |
| 8250304 | Conical Point | | | | | | | 192.00 |
| * SOOSAN SB35 | | | | | | | | |
| 8250400 | Blunt End | | 23 5/8" | 2.3400 | | 1 | 1.739 | 199.00 |
| 8250401 | Flat Chisel Cross Cut | | | | | | | 199.00 |
| 8250402 | Flat Chisel In Line | | | | | | | 199.00 |
| 8250403 | Moil Point | | | | | | | 199.00 |
| 8250404 | Conical Point | | | | | | | 199.00 |
| * SOOSAN SB40 | | | | | | | | |
| 8250500 | Blunt End | | 27 1/2" | 2.6600 | | 1 | 1.943 | 316.00 |
| 8250501 | Flat Chisel Cross Cut | | | | | | | 316.00 |
| 8250502 | Flat Chisel In Line | | | | | | | 316.00 |
| 8250503 | Moil Point | | | | | | | 316.00 |
| 8250504 | Conical Point | | | | | | | 316.00 |
| * SOOSAN SB43 | | | | | | | | |
| 8250600 | Blunt End | | 30" | 2.9250 | | 1 | 2.285 | 369.00 |
| 8250601 | Flat Chisel Cross Cut | | | | | | | 369.00 |
| 8250602 | Flat Chisel In Line | | | | | | | 369.00 |
| 8250603 | Moil Point | | | | | | | 369.00 |
| 8250604 | Conical Point | | | | | | | 369.00 |
| AJAX TAMPING PADS - stems sold seperately | | | | | | | | |
| 8000001 | 8"x8" Square Tamping Pad | | | | | | | \$750.00 |
| 8000002 | 12"x12" Square Tamping Pad | | | | | | | \$1,100.00 |

**Note other point styles and lengths available upon request.



DEMOLITION TOOL PRICING



| PART No. | Point Description | WT lbs | O.A.L. | DIA. inch | Collar inch | No. of Slots | Shank Dia. In. | LIST PRICE |
|---|----------------------------|--------|---------|-----------|-------------|--------------|----------------|------------|
| * STANLEY MB 125 | | | | | | | | |
| 8180200 | Blunt End | 11 | 19" | 1.7320 | | 1 | 1.1810 | 123,123.00 |
| 8180201 | Flat Chisel Cross Cut | | | | | | | 123.00 |
| 8180202 | Flat Chisel In Line | | | | | | | 123.00 |
| 8180203 | Moil Point | | | | | | | 123.00 |
| 8180204 | Conical Point | | | | | | | 123.00 |
| * STANLEY MB 156 | | | | | | | | |
| 8181800 | Blunt End | | 17 1/2" | 1.7510 | | 1 | | 109.00 |
| 8181801 | Flat Chisel Cross Cut | | | | | | | 109.00 |
| 8181802 | Flat Chisel In Line | | | | | | | 109.00 |
| 8181803 | Moil Point | | | | | | | 109.00 |
| 8181804 | Conical Point | | | | | | | 109.00 |
| * STANLEY MB 250/258/350/356 Same as Bobcat 2500/2570/3570 | | | | | | | | |
| 8180300 | Blunt End | 29 | 22 | 2.5000 | | 1 | | 201.00 |
| 8180301 | Flat Chisel Cross Cut | | | | | | | 201.00 |
| 8180302 | Flat Chisel In Line | | | | | | | 201.00 |
| 8180303 | Moil Point | | | | | | | 201.00 |
| 8180304 | Conical Point | | | | | | | 201.00 |
| * STANLEY MB 506 Same as SOOSAN SB40 | | | | | | | | |
| 8180700 | Blunt End | 42 | 29 | 2.6380 | | 1 | 1.9690 | 318.00 |
| 8180701 | Flat Chisel Cross Cut | | | | | | | 318.00 |
| 8180702 | Flat Chisel In Line | | | | | | | 318.00 |
| 8180703 | Moil Point | | | | | | | 318.00 |
| 8180704 | Conical Point | | | | | | | 318.00 |
| * STANLEY MB 550 | | | | | | | | |
| 8180400 | Blunt End | 42 | 29" | 2.7560 | | 1 | | 323.00 |
| 8180401 | Flat Chisel Cross Cut | | | | | | | 323.00 |
| 8180402 | Flat Chisel In Line | | | | | | | 323.00 |
| 8180403 | Moil Point | | | | | | | 323.00 |
| 8180404 | Conical Point | | | | | | | 323.00 |
| * STANLEY MB 656/675/695 | | | | | | | | |
| 8181600 | Blunt End | | 28 | 3.0000 | | 1 | | 370.00 |
| 8181601 | Flat Chisel Cross Cut | | | | | | | 370.00 |
| 8181602 | Flat Chisel In Line | | | | | | | 370.00 |
| 8181603 | Moil Point | | | | | | | 370.00 |
| 8181604 | Conical Point | | | | | | | 370.00 |
| * STANLEY MB 800/875 | | | | | | | | |
| 8180500 | Blunt End | | 29 | 3.1250 | | 2 | | 415.00 |
| 8180501 | Flat Chisel Cross Cut | | | | | | | 415.00 |
| 8180502 | Flat Chisel In Line | | | | | | | 415.00 |
| 8180503 | Moil Point | | | | | | | 415.00 |
| 8180504 | Conical Point | | | | | | | 415.00 |
| * STANLEY MB 30/EX/EXS | | | | | | | | |
| 8180900 | Blunt End | | 41 1/2" | 3.905" | | 2 | 3.00 | 959.00 |
| 8180901 | Flat Chisel Cross Cut | | | | | | | 959.00 |
| 8180902 | Flat Chisel In Line | | | | | | | 959.00 |
| 8180903 | Moil Point | | | | | | | 959.00 |
| 8180904 | Conical Point | | | | | | | 959.00 |
| * STANLEY MB 50/EX/EXS | | | | | | | | |
| 8181100 | Blunt End | | 48" | 5.8780 | | 2 | 4.6900 | 1,599.00 |
| 8181101 | Flat Chisel Cross Cut | | | | | | | 1,599.00 |
| 8181102 | Flat Chisel In Line | | | | | | | 1,599.00 |
| 8181103 | Moil Point | | | | | | | 1,599.00 |
| 8181104 | Conical Point | | | | | | | 1,599.00 |
| * STANLEY MB 60/EX/EXS | | | | | | | | |
| 8181200 | Blunt End | 287 | 46 | 5.8780 | | 2 | 4.6900 | 1,540.00 |
| 8181201 | Flat Chisel Cross Cut | | | | | | | 1,540.00 |
| 8181202 | Flat Chisel In Line | | | | | | | 1,540.00 |
| 8181203 | Moil Point | | | | | | | 1,540.00 |
| 8181204 | Conical Point | | | | | | | 1,540.00 |
| AJAX TAMPING PADS - stems sold seperately | | | | | | | | |
| 8000001 | 8"x8" Square Tamping Pad | | | | | | | \$750.00 |
| 8000002 | 12"x12" Square Tamping Pad | | | | | | | \$1,100.00 |

**Note other point styles and lengths available upon request.



DEMOLITION TOOL PRICING

| PART No. | Point Description | WT lbs | O.A.L. | DIA. inch | Collar inch | No. of Slots | Shank Dia. In. | LIST PRICE |
|--|----------------------------|--------|---------|-----------|-------------|--------------|----------------|------------|
| * STANLEY MB 80/EX/EXS | | | | | | | | |
| 8181400 | Blunt End | | 52" | 6.4520 | | 2 | 5.1000 | 2,201.00 |
| 8181401 | Flat Chisel Cross Cut | | | | | | | 2,201.00 |
| 8181402 | Flat Chisel In Line | | | | | | | 2,201.00 |
| 8181403 | Moil Point | | | | | | | 2,201.00 |
| 8181404 | Conical Point | | | | | | | 2,201.00 |
| * TRAMAC BRH 125 | | | | | | | | |
| 8200900 | Blunt End | 46 | 27 1/2" | 3.1500 | | 2 | 2.5590 | 403.00 |
| 8200901 | Flat Chisel Cross Cut | | | | | | | 403.00 |
| 8200902 | Flat Chisel In Line | | | | | | | 403.00 |
| 8200903 | Moil Point | | | | | | | 403.00 |
| 8200904 | Conical Point | | | | | | | 403.00 |
| * TRAMAC BRH 250/270 | | | | | | | | |
| 8201000 | Blunt End | 93 | 33" | 3.7010 | | 2 | | 629.00 |
| 8201001 | Flat Chisel Cross Cut | | | | | | | 629.00 |
| 8201002 | Flat Chisel In Line | | | | | | | 629.00 |
| 8201003 | Moil Point | | | | | | | 629.00 |
| 8201004 | Conical Point | | | | | | | 629.00 |
| * TRAMAC BRH 501/570 | | | | | | | | |
| 8201100 | Blunt End | 159 | 39 1/2" | 4.4880 | | 2 | | 939.00 |
| 8201101 | Flat Chisel Cross Cut | | | | | | | 939.00 |
| 8201102 | Flat Chisel In Line | | | | | | | 939.00 |
| 8201103 | Moil Point | | | | | | | 939.00 |
| 8201104 | Conical Point | | | | | | | 939.00 |
| * TRAMAC BRH 620 | | | | | | | | |
| 8201200 | Blunt End | 168 | 41 1/2" | 4.4600 | | 2 | 3.8050 | 989.00 |
| 8201201 | Flat Chisel Cross Cut | | | | | | | 989.00 |
| 8201202 | Flat Chisel In Line | | | | | | | 989.00 |
| 8201203 | Moil Point | | | | | | | 989.00 |
| 8201204 | Conical Point | | | | | | | 989.00 |
| * TRAMAC BRH 625/BRM 900 | | | | | | | | |
| 8201300 | Blunt End | 154 | 39 1/2" | 4.6150 | | 2 | 3.9880 | 973.00 |
| 8201301 | Flat Chisel Cross Cut | | | | | | | 973.00 |
| 8201302 | Flat Chisel In Line | | | | | | | 973.00 |
| 8201303 | Moil Point | | | | | | | 973.00 |
| 8201304 | Conical Point | | | | | | | 973.00 |
| * TRAMAC BRH 750 | | | | | | | | |
| 8201400 | Blunt End | 190 | 43 1/2" | 4.7240 | | 2 | 3.9370 | 1,221.00 |
| 8201401 | Flat Chisel Cross Cut | | | | | | | 1,221.00 |
| 8201402 | Flat Chisel In Line | | | | | | | 1,221.00 |
| 8201403 | Moil Point | | | | | | | 1,221.00 |
| 8201404 | Conical Point | | | | | | | 1,221.00 |
| * TRAMAC BRH 1100 | | | | | | | | |
| 8201600 | Blunt End | 298 | 53" | 5.5120 | | 2 | 4.5280 | 2,139.00 |
| 8201601 | Flat Chisel Cross Cut | | | | | | | 2,139.00 |
| 8201602 | Flat Chisel In Line | | | | | | | 2,139.00 |
| 8201603 | Moil Point | | | | | | | 2,139.00 |
| 8201604 | Conical Point | | | | | | | 2,139.00 |
| TRAMAC BRP 30 | | | | | | | | |
| 8200100 | Blunt End | 8 | 16" | 1.5750 | | 1 | | 101.00 |
| 8200101 | Flat Chisel Cross Cut | | | | | | | 101.00 |
| 8200102 | Flat Chisel In Line | | | | | | | 101.00 |
| 8200103 | Moil Point | | | | | | | 101.00 |
| 8200104 | Conical Point | | | | | | | 101.00 |
| TRAMAC BRP 40 | | | | | | | | |
| 8200200 | Blunt End | 11 | 19 1/2" | 1.7720 | | 2 | 1.4960 | 145.00 |
| 8200201 | Flat Chisel Cross Cut | | | | | | | 145.00 |
| 8200202 | Flat Chisel In Line | | | | | | | 145.00 |
| 8200203 | Moil Point | | | | | | | 145.00 |
| 8200204 | Conical Point | | | | | | | 145.00 |
| AJAX TAMPING PADS - stems sold seperately | | | | | | | | |
| 8000001 | 8"x8" Square Tamping Pad | | | | | | | \$750.00 |
| 8000002 | 12"x12" Square Tamping Pad | | | | | | | \$1,100.00 |

**Note other point styles and lengths available upon request.



DEMOLITION TOOL PRICING

| PART No. | Point Description | WT lbs | O.A.L. | DIA. inch | Collar inch | No. of Slots | Shank Dia. In. | LIST PRICE |
|----------|--|-------------------------------|---------|-----------|-------------|--------------|----------------|------------|
| | TRAMAC BRP 50/45 | | | | | | | |
| 8200300 | Blunt End | 12 | 17" | 1.9690 | | 1 | | 124.00 |
| 8200301 | Flat Chisel Cross Cut | | | | | | | 124.00 |
| 8200302 | Flat Chisel In Line | | | | | | | 124.00 |
| 8200303 | Moil Point | | | | | | | 124.00 |
| 8200304 | Conical Point | | | | | | | 124.00 |
| | * TRAMAC BRP 60/70 | | | | | | | |
| 8200500 | Blunt End | 14 | 20" | 1.9690 | | 1 | | 141.00 |
| 8200501 | Flat Chisel Cross Cut | | | | | | | 141.00 |
| 8200502 | Flat Chisel In Line | | | | | | | 141.00 |
| 8200503 | Moil Point | | | | | | | 141.00 |
| 8200504 | Conical Point | | | | | | | 141.00 |
| | * TRAMAC BRP 75/76/90/91 | | | | | | | |
| 8200600 | Blunt End | 20 | 21 1/2" | 2.3620 | | 2 | 1.8500 | 217.00 |
| 8200601 | Flat Chisel Cross Cut | | | | | | | 217.00 |
| 8200602 | Flat Chisel In Line | | | | | | | 217.00 |
| 8200603 | Moil Point | | | | | | | 217.00 |
| 8200604 | Conical Point | | | | | | | 217.00 |
| | * TRAMAC BRP 85/95/100 | Same as Bobcat 850/950 | | | | | | |
| 8200700 | Blunt End | 26 | 23 1/2" | 2.4410 | | 2 | | 265.00 |
| 8200701 | Flat Chisel Cross Cut | | | | | | | 265.00 |
| 8200702 | Flat Chisel In Line | | | | | | | 265.00 |
| 8200703 | Moil Point | | | | | | | 265.00 |
| 8200704 | Conical Point | | | | | | | 265.00 |
| | * TRAMAC BRP 130/140/150 | | | | | | | |
| 8200800 | Blunt End | 44 | 28 1/2" | 2.9130 | | 2 | | 366.00 |
| 8200801 | Flat Chisel Cross Cut | | | | | | | 366.00 |
| 8200802 | Flat Chisel In Line | | | | | | | 366.00 |
| 8200803 | Moil Point | | | | | | | 366.00 |
| 8200804 | Conical Point | | | | | | | 366.00 |
| | * TRAMAC BRV 32/V32/V1200 | | | | | | | |
| 8201500 | Blunt End | 198 | 43 1/2" | 4.8030 | | 2 | | 1,154.00 |
| 8201501 | Flat Chisel Cross Cut | | | | | | | 1,154.00 |
| 8201502 | Flat Chisel In Line | | | | | | | 1,154.00 |
| 8201503 | Moil Point | | | | | | | 1,154.00 |
| 8201504 | Conical Point | | | | | | | 1,154.00 |
| | TRAMAC BRV 43 | | | | | | | |
| 8201700 | Blunt End | 355 | 51" | 5.8660 | | 2 | | 2,101.00 |
| 8201701 | Flat Chisel Cross Cut | | | | | | | 2,101.00 |
| 8201702 | Flat Chisel In Line | | | | | | | 2,101.00 |
| 8201703 | Moil Point | | | | | | | 2,101.00 |
| 8201704 | Conical Point | | | | | | | 2,101.00 |
| | * TRAMAC BRV 45 | | | | | | | |
| 8202100 | Blunt End | | 48" | 5.8950 | | 2 | | 2,246.00 |
| 8202101 | Flat Chisel Cross Cut | | | | | | | 2,246.00 |
| 8202102 | Flat Chisel In Line | | | | | | | 2,246.00 |
| 8202103 | Moil Point | | | | | | | 2,246.00 |
| 8202104 | Conical Point | | | | | | | 2,246.00 |
| | * TRAMAC BRV 52 | | | | | | | |
| 8201800 | Blunt End | 423 | 53" | 6.3780 | | 2 | | 3,015.00 |
| 8201801 | Flat Chisel Cross Cut | | | | | | | 3,015.00 |
| 8201802 | Flat Chisel In Line | | | | | | | 3,015.00 |
| 8201803 | Moil Point | | | | | | | 3,015.00 |
| 8201804 | Conical Point | | | | | | | 3,015.00 |
| | TRAMAC BRV 53 | | | | | | | |
| 8201900 | Blunt End | 553 | 61" | 6.6540 | | 2 | | 3,414.00 |
| 8201901 | Flat Chisel Cross Cut | | | | | | | 3,414.00 |
| 8201902 | Flat Chisel In Line | | | | | | | 3,414.00 |
| 8201903 | Moil Point | | | | | | | 3,414.00 |
| 8201904 | Conical Point | | | | | | | 3,414.00 |
| | AJAX TAMPING PADS - stems sold seperately | | | | | | | |
| 8000001 | 8"x8" Square Tamping Pad | | | | | | | \$750.00 |
| 8000002 | 12"x12" Square Tamping Pad | | | | | | | \$1,100.00 |

**Note other point styles and lengths available upon request.



DEMOLITION TOOL PRICING

| PART No. | Point Description | WT lbs | O.A.L. | DIA. inch | Collar inch | No. of Slots | Shank Dia. In. | LIST PRICE |
|--|----------------------------|--------|--------|-----------|-------------|--------------|----------------|------------|
| * TRAMAC BRV 65 | | | | | | | | |
| 8202000 | Blunt End | | 71 | 7.9450 | | 2 | 7.9250 | 6,124.00 |
| 8202001 | Flat Chisel Cross Cut | | | | | | | 6,124.00 |
| 8202002 | Flat Chisel In Line | | | | | | | 6,124.00 |
| 8202003 | Moil Point | | | | | | | 6,124.00 |
| 8202004 | Conical Point | | | | | | | 6,124.00 |
| TRAMAC Z 96A | | | | | | | | |
| 8200400 | Blunt End | | | 2.3620 | | 1 | | 249.00 |
| 8200401 | Flat Chisel Cross Cut | | | | | | | 249.00 |
| 8200402 | Flat Chisel In Line | | | | | | | 249.00 |
| 8200403 | Moil Point | | | | | | | 249.00 |
| 8200404 | Conical Point | | | | | | | 249.00 |
| AJAX TAMPING PADS - stems sold seperately | | | | | | | | |
| 8000001 | 8"x8" Square Tamping Pad | | | | | | | \$750.00 |
| 8000002 | 12"x12" Square Tamping Pad | | | | | | | \$1,100.00 |

**Note other point styles and lengths available upon request.

AJAX TOOL WORKS, INC.
 10801 FRANKLIN AVENUE FRANKLIN PARK, ILLINOIS 60131
 847-455-5420 TOLL FREE 800-323-9129 FAX 847-455-9242 800-424-2529

www.ajaxtools.com

info@ajaxtools.com

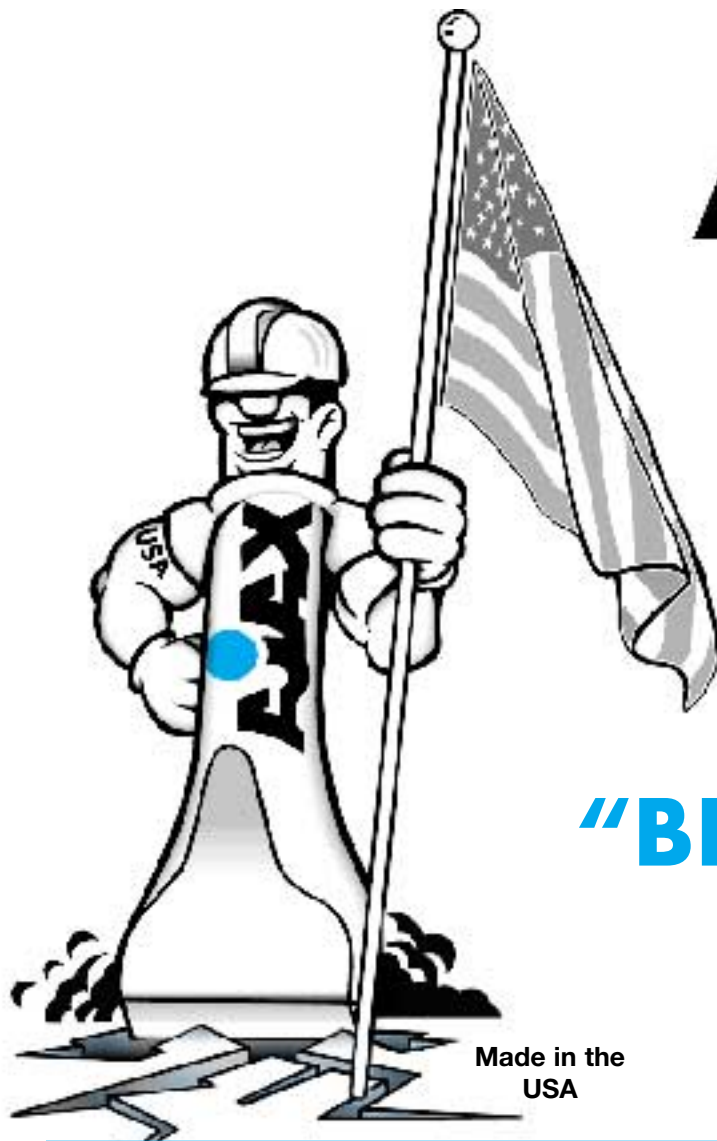

Made in the
USA

AJAX Tools

Hydraulic Mounted Percussion Tools

Delivering Value
Through
Performance

“BLOW BY BLOW”

An American Manufacturer
Since 1946

Care of Hydraulic Breaker Bits:

- Evaluate tool condition prior to each application:
 - Remove from service all bits with cracks, bent, mushroomed shanks & excessive wear.
- Evaluate internal hammer bushings & all wear surfaces:
 - Follow all manufacturer's recommended schedules.
- Lubricate tool prior to mounting in hammer and during use:
 - Use grease recommended by Hydraulic Hammer Mfg. only.
- Train personnel on the correct use and limits of Hydraulic Breakers.

Point Styles, Application & Proper Use:

BLUNT PT., quarries & slab busting / FLAT PT., trenching / MOIL PT, concrete & pavement.

*Special application Tools available upon request.

- Evaluate application; use the correct size Hydraulic Breaker & Point Style for best performance.
- Never pry, side-loading tools will cause breakage and uneven wear on tools & hammer.
- Maintain constant perpendicular pressure to work surface:
 - Bouncing or side deflection will cause premature metal fatigue.
- Don't over work tool bit; take smaller bites, working from outer edge to center of object.
- Don't allow Hydraulic Hammer to be free or blank fired.

AJAX Tools

Ajax Tool Works Incorporated

10801 Franklin Ave. • Franklin Park, IL 60131

847/455-5420 • 800/323-9129

847/455-9242 • 800/424-2529 toll free fax

www.ajaxtools.com • info@ajaxtools.com

